

release 05/1997

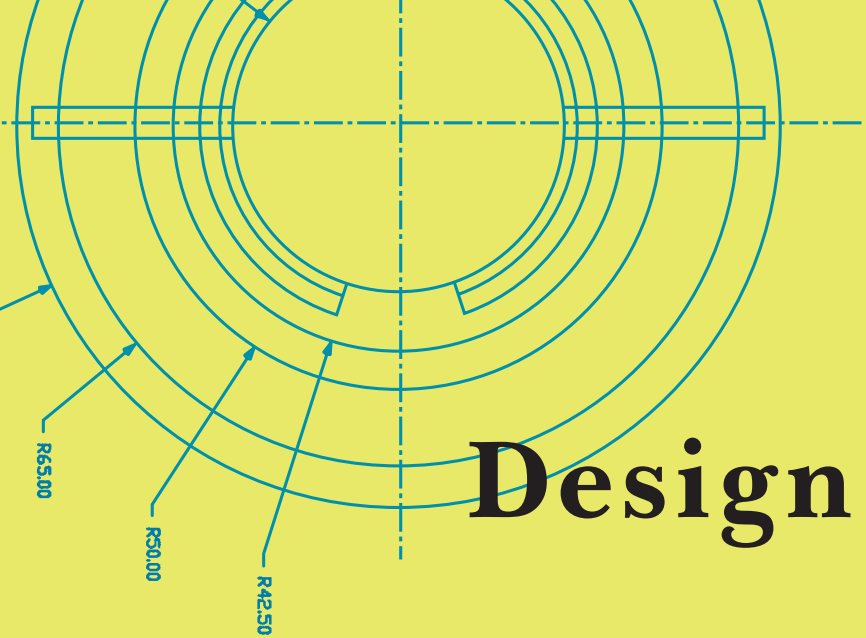

Design *guide*

contents

update



GE Plastics

Design *guide*

release 05/1997



Contents

General Introduction

1	Design Development	9
<u>1.1</u>	Introduction	9
<u>1.2</u>	Material design factors	9
<u>1.3</u>	Development steps	9
<u>1.3.1</u>	End-use requirements	9
<u>1.3.2</u>	Preliminary design	10
<u>1.3.3</u>	Material selection	10
<u>1.3.4</u>	Design modification	10
<u>1.3.5</u>	CAD/CAE	10
<u>1.3.5.1</u>	<i>Flow analysis</i>	10
<u>1.3.5.2</u>	<i>Stress analysis</i>	11
<u>1.3.6</u>	Prototyping and testing	11
<u>1.3.7</u>	End-use testing	11
2	Design for stiffness	13
<u>2.1</u>	Introduction	13
<u>2.2</u>	How to determine stiffness	13
<u>2.2.1</u>	Material	13
<u>2.2.2</u>	Geometry & loading	14
<u>2.2.3</u>	Other factors influencing stiffness	14
<u>2.2.4</u>	Calculating the stiffness	15
<u>2.2.5</u>	Modal analysis	15
<u>2.2.6</u>	Safety factors	15
<u>2.3</u>	Increasing part stiffness	15
<u>2.3.1</u>	Ribs	15
<u>2.3.2</u>	V-grooves	15
<u>2.3.3</u>	Corrugation	16
<u>2.4</u>	Optimization of stiffness	16
<u>2.4.1</u>	Optimization for part weight	16
<u>2.4.1.1</u>	<i>Material Selection</i>	16
<u>2.4.1.2</u>	<i>Geometric considerations</i>	16
<u>2.4.2</u>	Optimization for stiffness to cost ratio	16
3	Design for strength	19
<u>3.1</u>	Introduction	19
<u>3.2</u>	Material Strength	19
<u>3.2.1</u>	Ultimate strength	20
<u>3.2.2</u>	Yield strength	20

<u>3.2.3</u>	Strain to failure	20
<u>3.2.4</u>	Proportional limit	20
<u>3.2.5</u>	Material toughness	20
<u>3.2.6</u>	Other measures	20
<u>3.3</u>	Effects of various factors on strenght	20
<u>3.3.1</u>	Other factors	20
<u>3.4</u>	Part Strength	21
<u>3.4.1</u>	Ultimate part strength	21
<u>3.4.2</u>	Part yield strength	22
<u>3.4.3</u>	Part toughness	22
<u>3.5</u>	Improving part strength	22
<u>3.5.1</u>	Material choice	22
<u>3.5.2</u>	Geometry optimization	23
<u>3.6</u>	Design considerations	23

4 Design for behaviour over time .. 25

<u>4.1</u>	Introduction	25
<u>4.2</u>	Static time dependent phenomena	25
<u>4.2.1</u>	Creep	25
<u>4.2.1.1</u>	<i>Creep recovery</i>	26
<u>4.2.1.2</u>	<i>Creep failure modes</i>	26
<u>4.2.1.3</u>	<i>Apparent modulus</i>	26
<u>4.2.2</u>	Stress relaxation	27
<u>4.2.3</u>	Design considerations	28
<u>4.3</u>	Dynamic time dependent phenomena	28
<u>4.3.1</u>	Fatigue	28
<u>4.3.1.1</u>	<i>Fatigue and endurance limits</i>	28
<u>4.3.1.2</u>	<i>Factors affecting fatigue</i>	29
<u>4.3.2</u>	Wear resistance	29
<u>4.3.2.1</u>	<i>Types of wear</i>	29
<u>4.3.2.2</u>	<i>Factors affecting wear</i>	29

5 Design for impact performance .. 31

<u>5.1</u>	Introduction	31
<u>5.2</u>	Common impact testing methods	31
<u>5.2.1</u>	Pendulum methods	32
<u>5.2.2</u>	Falling weight methods	32
<u>5.3</u>	Design considerations	33

6	Design for appearance	35
<u>6.1</u>	Introduction	35
<u>6.1.1</u>	General remarks	35
<u>6.2</u>	Surface defects	35
<u>6.2.1</u>	Sink marks	35
<u>6.2.2</u>	Weld lines	35
<u>6.2.3</u>	Air traps	35
<u>6.2.4</u>	Voids	36
<u>6.2.5</u>	Streaks	36
<u>6.2.6</u>	Delamination	36
<u>6.2.7</u>	Jetting	36
<u>6.2.8</u>	Gate marks	36
<u>6.2.9</u>	Summary	37
7	Design for precision	39
<u>7.1</u>	Introduction	39
<u>7.1.1</u>	Mould shrinkage	39
<u>7.1.2</u>	Secondary effects	39
<u>7.2</u>	Shrinkage phenomena	39
<u>7.2.1</u>	Cooling	39
<u>7.2.2</u>	Packing	40
<u>7.2.3</u>	Orientation	40
<u>7.3</u>	Materials and shrinkage	40
<u>7.3.1</u>	Amorphous materials	40
<u>7.3.2</u>	Crystalline materials	41
<u>7.3.3</u>	Reinforced materials	41
<u>7.4</u>	Design related factors	41
<u>7.4.1</u>	Part wall thickness	41
<u>7.4.2</u>	Ribs	41
<u>7.5</u>	Mould related factors	41
<u>7.5.1</u>	Gate location	41
<u>7.5.2</u>	Gate type	42
<u>7.5.3</u>	Gate size	42
<u>7.6</u>	Processing related factors	42
<u>7.6.1</u>	Melt temperature	42
<u>7.6.2</u>	Mould temperature	42
<u>7.6.3</u>	Injection time	42
<u>7.6.4</u>	Packing pressure	42
<u>7.7</u>	Secondary effects	42
<u>7.7.1</u>	Thermal expansion	42
<u>7.7.2</u>	Moisture absorption	42

7.7.3	Post crystallization	42
7.7.4	Creep under load	42
7.8	Simulation techniques	42
7.9	Summary	43

8 Design for mouldability 45

8.1	Introduction	45
8.2	Material issues	45
8.2.1	Melt flow length	45
8.2.1.1	<i>Viscosity</i>	45
8.2.1.2	<i>Thermal properties</i>	46
8.2.1.3	<i>Shear properties</i>	46
8.2.2	Melt temperature	46
8.3	Shrinkage	46
8.3.1	General remarks	46
8.3.2	Warpage	47
8.4	Cooling time	47
8.5	Design considerations	48
8.5.1	General remarks	48
8.5.2	Nominal wall thickness	48
8.5.3	Projections	48
8.5.4	Radii	49
8.5.5	Ribs	49
8.5.6	Support ribs	49
8.5.7	Bosses	50
8.5.8	Undercuts	50
8.5.9	Coring	51
8.5.10	Draft angles	51
8.5.11	Textures & lettering	51
8.5.12	Flow leaders	52
8.5.13	Moulded-in-stress	52
8.5.14	Weld lines	52
8.6	Processing considerations	52
8.6.1	Venting	52
8.6.2	Gating	53
8.7	Ejection	54

9 Design for recyclability 55

10 Design for automation 57

11 Appendix 59

Introduction

The intention of this guide is to provide the design and engineering communities with an insight into the considerations necessary when designing applications in engineering thermoplastics. Many of these considerations relate to moulding criteria, so those involved in the manufacturing and processing of plastics components should also find it useful.

Typically, design manuals deal with a specific resin family, presenting properties, design criteria, assembly and other related information. GE Plastics' product line includes crystalline, amorphous, thermoplastic elastomers and glass mat reinforced polymers. Because of this diversity, this brochure will concentrate on issues common to all injection mouldable thermoplastic resins.

This design guide differs from most by virtue of its 'Designing for' concept, helping the reader move quickly to the issue that needs addressing.

Consequently, discussion of certain aspects can occur in more than one section, which demonstrates how integral the process of designing for plastics is. Following the explanatory chapters is a section showing typical engineering material performance graphs for a range of GE Plastics thermoplastic polymers.

Supplementary publications covering assembly techniques, polymer processing considerations and overviews of specific resins in the GE Plastics product lines are available on request. In addition, monographs discussing detailed design studies are released periodically, covering these issues in greater depth than is possible in this generalized guide.

Design development

1.1 Introduction

Throughout the process of product design, both functional and material aspects must be considered. Functional design factors relate to production and assembly. Material design factors concern the performance of a material in service. This performance, which includes strengths, weaknesses and limitations, is investigated to provide the starting point of the design process.

1.2 Material design factors

Considerable information is needed by the design engineer to develop a product design from the initial concept. This can be a smooth process if careful attention is given to each step involved. The designer must know the end-use performance requirements of the proposed application. To determine whether a material can meet these requirements, the designer must be able to rely on information provided by the raw material supplier, indicating the environmental and physical capabilities of the material.

1.3 Development steps

1.3.1 Establish end-use requirements

The development of any component starts with careful consideration of anticipated end-use requirements. In general, the lower strength properties of polymers compared with metals and woods require that products be designed to utilize a larger percentage of their available strength.

Specific information needed to establish end-use requirements includes:

(a) Anticipated structural requirements

LOADS

These dictate the stresses a material will be subjected to, and they define component deflections.

RATE OF LOADING

A thermoplastic may demonstrate different behaviour with changes in loading rate. Therefore, in addition to its magnitude, the rate at which loading is applied should be investigated.

DURATION OF LOADING

Initial negligible deflections resulting from a small load may become unacceptably large if the load is maintained.

IMPACT FORCES

Because the application of high loads for short periods of time may result in premature failure, the nature of impact forces to which the component will be subjected should be determined.

VIBRATION

This induces stress and deflection changes. Though these may be small, component failure may occur through constant repetition.

FORESEEABLE MISUSE

Though structural requirements may have been satisfied, and an appropriate design proposed, failure can still occur as a result of misuse. To establish the anticipated risk level, therefore, a 'risk assessment' of the product in use should be made.

The 'relevance tree' method is ideal for this purpose, providing data to facilitate assessment of foreseeable misuse. The results should then be

weighed against the financial aspects of the product. This exercise is often called 'Product Risk Analysis'. Additional details are not given here since each company applies its own measures.

General Electric Plastics is prepared to provide assistance in this matter and, if required, contact should be made with the nearest GE Plastics' sales office.

(b) Anticipated environments

TEMPERATURE EXTREMES

All materials possess a working temperature range. Outside this range the component cannot properly perform its intended function. In addition, the properties of the material may vary considerably within working limits.

As all thermoplastics are subject to attack by certain chemical agents, the service environment of the proposed component must be established.

Outdoor exposure for prolonged periods may result in material degradation.

(c) Assembly and secondary operations

Usually a plastic component is not used in isolation but is just one of a number of components making up the end-product. The technique used for assembly, such as mechanical fastening, welding and adhesive bonding, needs to be considered at the initial design stage to optimize the component for ease of assembly, (and ease of handling in the case of automated assembly), or ease of disassembly for maintenance and recycling.

Secondary operations, such as painting, printing and hot stamping, also have to be given early consideration in order to design the best surface profile. This means avoiding for example sink marks and sharp changes in shape to achieve a high quality smooth surface.

(d) Cost limits

The following should be established:

- Component cost resulting in profitable sales
- Annual volume
- Economic processing method(s) with estimated cycle time(s)
- Tooling cost(s) for selected processing method(s)
- The expected service life of the component

(e) Regulations/standards compliance

Check which standards or regulations apply or can be applied in the market place to the component, product or appliance, for example:

STANDARDS

IEC/CEE International Electrical Committee/Comité Européen d'Electricité

ISO/CEN International Standards Organization/Comité Européen de Normalisation

DIN Deutsche Industrie für Normungen

BSI British Standards Institute

NF Normes Français

ASTM American Society for Testing of Materials

REGULATIONS

UL Underwriters Laboratories

CSA Canadian Standards Association

CEE Publications of the Comité Européen d'Electricité

Factory and building codes.

1.3.2 Establish a preliminary design

A preliminary concept sketch of the proposed component can help the designer to determine which aspects are inflexible, and which can be modified to achieve required performance. The preliminary sketch, therefore, should include both fixed and variable dimensions.

1.3.3 Select the material

A GE Plastics' material should be selected that will satisfy initially defined, end-use requirements. The comparative property data sheet should be the first document which is consulted. Initial selection may subsequently be refined by reviewing the time, temperature and environment-dependent properties relevant to the particular application. Supplementary data, such as abrasion resistance or ductility, may be needed to confirm the selection.

Material properties can be divided into two main categories.

(a) Mechanical properties used essentially for component design calculations:

- Elastic limit
- Tensile strength
- Modulus vs temperature
- Poisson's ratio
- Apparent (creep) modulus
- Fatigue limit
- Coefficient(s) of thermal expansion
- Coefficient of friction
- Thermal conductivity
- Density
- Mould shrinkage

(b) Other relevant properties:

- Hardness
- Impact strength
- Chemical resistance
- Weathering resistance
- Abrasion resistance
- Ductility
- Flammability
- Heat deflection temperature
- Electrical properties

To design a plastic component, information concerning any combination of material properties may be required. If the data are unavailable, or assistance is needed in interpretation, contact should be made with the nearest GE Plastics' sales office.

1.3.4 Modify the design

If this is necessary, four areas in particular should be considered:

- (a) The specific property balance of the selected grade, (e.g. tensile strength, impact resistance)
- (b) Processing limitations, (e.g. wall thickness vs flow lengths)
- (c) Assembly methods, (e.g. snap-fits, adhesives)
- (d) Cost of modification and its impact on component and/or project budget, (refer to ■ FIGURE 1).

Strength of materials formulae should be used in conjunction with material property data to calculate necessary dimensions such as wall thickness. (Refer to Chapter 3 'Design for strength'). Design calculations of a repetitive or iterative nature, however, may warrant a computer-aided approach.

1.3.5 CAD/CAE

Two particularly relevant computer-aided systems are Flow Analysis of an injection moulding, and Stress Analysis of a final component. Both generally use the Finite Element Method. This approach considers the geometry and physical properties of the component as a continuum of small manageable parts, or finite elements. Each element of the structure is individually investigated in relation to its neighbouring elements, the total structure, and the physical constraints on the system. A large number of simultaneous equations result, the solution of which is particularly suited to the repetitive capabilities of a computer.

1.3.5.1 Flow analysis

Because the performance of an injection moulded component is largely dependent on the moulding process, consideration of the service conditions of the component in isolation is insufficient to ensure a successful product. Simple shapes should not give material flow problems to the experienced tool-maker and moulder. However, larger components of complex geometry often present difficulties, for example positioning and number of gates, runner dimensions and location of weld lines.

In the flow analysis process, a computer model of the component is produced, and initial gating positions selected. The predicted manner in which the material will fill the cavity is then presented graphically and numerically. Isochronous temperatures and pressures throughout the system are calculated, in addition to weld line locations and undesirable conditions such as overpacking. Moulding variables and/or gating positions are subsequently changed, if necessary, in order to achieve an optimum flow pattern.

By means of this iterative approach, analyses of different options are possible before commitment to actual tool production. Moreover, processing difficulties are identified and may be rectified at the design stage.

Nowadays, flow simulation is not the only software available to the designer. Other injection moulding related software prediction tools include: warpage, mould cooling, fibre orientation, (for example for glass-filled thermoplastics), moulded-in stresses and many more.

1.3.5.2 Stress analysis

A component in service will be subjected to forces which induce stresses in the material. To ensure that failure resulting from overstressing does not occur, it is essential that the stresses do not exceed recommended design limits.

As with Flow Analysis, the investigation of a simple geometry should not present any difficulty, since equations which can often be solved by substitution have been derived for many commonly encountered situations. However, the analysis of a complex geometry, though not generally suitable for this approach, may be solved by the finite element method. A mathematical model of the component, defining the geometry by x, y and z co-ordinates, is first described, together with the properties of the material. The boundary and loading conditions are then entered and specific output requested. Stresses in a particular area may be of interest for example.

Numerical values of deflections, diagrams of the distorted structure and of stress distribution may also contribute to a useful investigation. By this method, areas of unacceptably high stress or deflection may be identified and suitably modified.

1.3.6 Prototyping and testing

At this point in the procedure, a prototype should be constructed. The prototype and its testing can help the designer by:

- Establishing confidence in the design by confirming that component requirements do not exceed design limits.
- Developing preliminary product performance information.
- Identifying potential problem areas in performance, manufacturing or assembly.
- Allowing pre-launch assessment and feedback from consumer trials.

In order to obtain useful results, particular attention should be paid to certain aspects of the testing:

- Proper analysis of component requirements.
- Close similarity to the proposed product, particularly in critical or suspect performance areas.
- Development of realistic simulated use and storage tests
- Commitment to the time and effort required for testing before product introduction

1.3.7 End-use testing

Tests should be conducted to simulate use and storage of the component. It should be established which tests reflect defined component requirements, and whether they can be conducted in the laboratory or in situ. Frequently, the test equipment developed can be used for future quality control testing.

Product performance tests can be conducted on functional prototypes or production parts. Since functional prototypes may be produced using non-production tooling or part modelling, caution must be exercised during testing and interpreting the results. The prototype may not behave in exactly the same manner as a production component. The initial production components should also be tested to confirm product performance testing.

Several specialized techniques, examples of which follow, can be used for product performance testing:

- Strain gauge analysis
- Brittle coating analysis
- Photoelasticity
- Stress analysis by thermal emission
- Infra-red light banks for radiant heat effect measurement
- Environmental chambers for thermal cycling
- Life testing under simulated use conditions
- Accelerated ageing under elevated temperature, high humidity, or ultraviolet radiation conditions
- Holography

Although computer-aided techniques allow accurate modelling of a proposed design, they should not exclude or replace finished part testing. The construction of a functional prototype is therefore advisable.

FIGURE 1
Influence of modification to designs

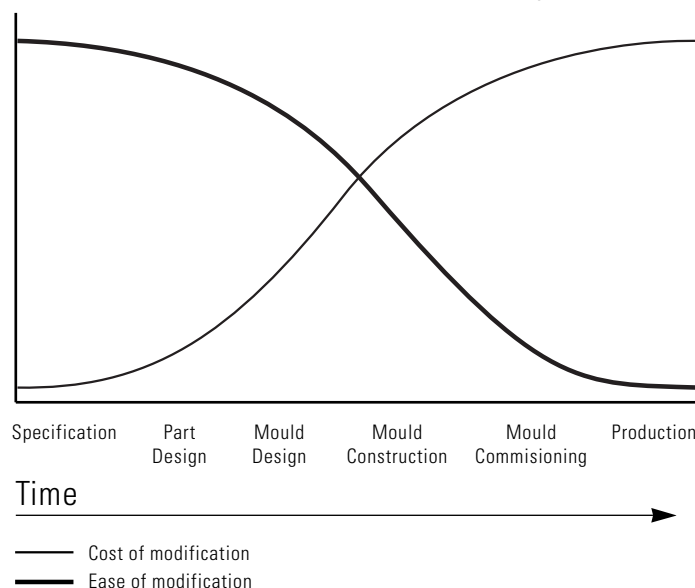

2

Design for stiffness

2.1 Introduction

The stiffness of a part is defined as the relationship between the load and the deflection of a part. This Chapter will discuss what modifications can be made to a part in order to influence and optimize stiffness. It will also give some guidelines of how the stiffness of a part can be calculated.

2.2 How to determine the stiffness

In general the stiffness of a part is determined by its material and its geometry.

2.2.1 Material

The most important material property for stiffness is the stress/strain curve. In general, the Young's modulus, which is determined from the stress/strain curve, is the best parameter to be used when comparing the stiffness of materials. However, when the Young's modulus is used, the stress/strain curve

is assumed to be linear. Especially for thermoplastics, the range in which the stress/strain curve can be estimated with a straight line is limited. For this reason, when a stiffness calculation of a part is made, it is necessary to check if the occurring stresses and strains still allow a linear approach. If this is not the case, it is advised to use a secant modulus for the stiffness calculation.

Consider ■ FIGURE 2. Suppose that the stiffness of a part is calculated using the Young's modulus Y . Suppose that a verification of the occurring stress results in the value σ . This value is clearly out of the range in which a linear approximation of the stress/strain curve is justified. In this case it is better to recalculate the stiffness of the part with the secant modulus Y^* .

Furthermore, it is important to consider the temperature at which the load is applied. For thermoplastics the stress/

strain curves are heavily dependent on temperature. It is advised to consider the stress/strain curve at the temperature at which the load is applied for the calculation of part stiffness.

Time also plays a role in the determination of the stiffness of a part. It can influence stiffness in one of two ways:

- (a) the material is loaded for a long time,
- (b) the material is loaded in cycles,
- (c) the material is loaded during a very short time.

The phenomena (a) and (b) are typically known as creep and fatigue. How these effects must be taken into account can be found in Chapter 4 'Design for behaviour over time'. Phenomenon (c) is known as impact. Refer to Chapter 5 'Design for impact'.

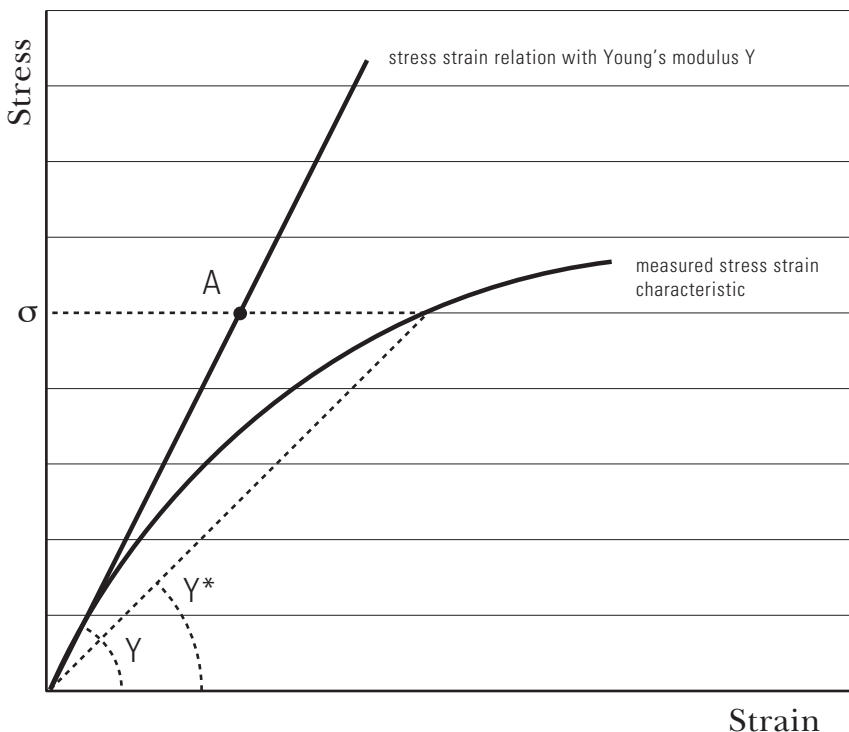

■ FIGURE 2
Accounting for material nonlinearities

■ FIGURE 3

A part loaded in tension

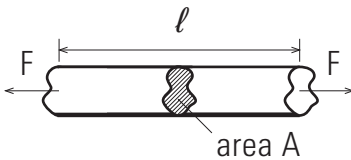

■ FIGURE 4

Cross section of a part

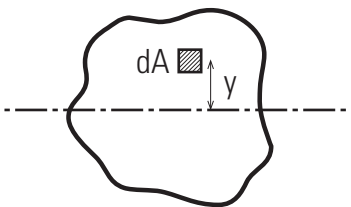

■ FIGURE 5

A rectangular cross-section

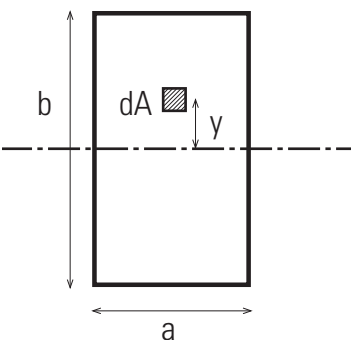

■ FIGURE 6

Clamped part loaded at the end

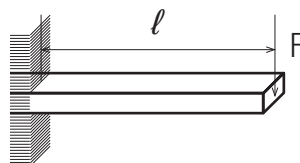

2.2.2 Geometry and loading

Besides the material, the geometry is also important for part stiffness. Which factors of the geometry are important is mainly determined by the type of loading. It should be noted that, in general, a part is loaded in more than one of the following types at the same time.

(a) Tensile loading

For a part loading in tension, (■ FIGURE 3), the cross-sectional area A and the length of the part l are important.

(b) Compressive loading

When a part is loaded under compression, again the cross-sectional area A and the length of the part are the geometrical parameters that determine the stiffness. In this case, buckling of the part is something that has to be considered separately.

(c) Flexural loading

For flexural loading, the moment of inertia and the length are the geometrical parameters that determine the stiffness. As can be seen in ■ FIGURE 4, the moment of inertia I is defined as:

$$I = \int_A y^2 dA$$

where y is the direction perpendicular to the neutral bending axis and A is the cross-sectional area. For example, for a rectangular cross-section, with the dimension a and b (■ FIGURE 5), I can be calculated with the formula mentioned above:

$$I = \int_A y^2 dA = \int_{-b/2}^{b/2} ay^2 dy = \frac{1}{3} a y^3 \Big|_{-b/2}^{b/2} = \frac{1}{12} a b^3$$

(d) Torsional loading

When a part is loaded in torsion, the polar moment of inertia and the length are the important geometrical parameters that determine stiffness. The polar moment of inertia I_p can be calculated with a similar formula to the moment of inertia.

As mentioned earlier, the stiffness of a construction is determined by the combination of the material and the geometry. The following two examples illustrate how the stiffness of a part can be calculated.

EXAMPLE 1

A part under tension

For a part of length l , and constant cross-sectional area A , the deflection f can be calculated with the formula:

$$f = F\ell / \gamma A$$

where F is the tension force and Y is the Young's modulus of the material. From this formula it can be seen that the stiffness of this part can be increased by decreasing I , increasing Y or increasing A .

EXAMPLE 2

A part under bending

For a part of length l and moment of inertia I , loaded by a force F at the end, (■ FIGURE 6), the deflection f at the end can be calculated using:

$$f = F\ell^3 / 3YI$$

where F is the force and Y the Young's modulus of the material. The stiffness of this part can be increased by decreasing l , increasing Y and increasing I . Suppose that the part has a rectangular cross-section. Then I is given by $1/12 ab^3$, (■ FIGURE 5). This means that I can be increased by increasing either a or b , though increasing b has a much larger effect.

2.2.3 Other factors influencing stiffness

Besides the geometry and the material, other important factors have an influence on stiffness, such as the type of loading or the restraints of the part. A load can, for instance, be concentrated on a point, but it can also be a pressure on an area. Different restraints that are used in calculations are clamped or simple supports. Note that, in reality, the fixing system will always be something in between fully clamped and simply supported.

2.2.4 Calculating the stiffness

Similar formulae to those given above are available for different cross-sections, for changing cross-sections, and so on. (Please refer to the Appendix for additional sources of reference).

The application of formulae is limited due to different factors:

- (a) The material behaviour is assumed to be linear, which means that the stress/strain curve of the material is a straight line.
- (b) The geometrical effects are assumed to be linear. For large deflections this leads to considerable inaccuracies.
- (c) The formulae given above assume a relatively simple shape.
- (d) In general, a part is not purely loaded in one mode, but in a combination of modes.

A simple way of accounting for material nonlinearities is already given above. Taking into account the other factors is more complicated. The simple formulae cannot be used anymore when these effects play an important role. If the part stiffness has to be determined for this type of problem, the only possibility is computer simulation using the finite element method. A computer model of the part has to be made and evaluated which requires much more time than hand calculations. Also, an appropriate computer system and software must be available.

In general, the following guidelines can be given:

- (a) For simple geometries and small deflections, hand calculations can be made.
- (b) For more complex geometries with small deflections, linear finite element analysis techniques can be used.
- (c) Only nonlinear geometrical finite element analysis can account for large deflections on complex geometries.

Note that the analysis costs increase dramatically when going from step (a) to step (c).

2.2.5 Modal Analysis

Vibration resistance is important for many applications such as automotive components. All parts designed in plastic or any other material will have eigenfrequencies. These eigenfrequencies will, amongst other factors, depend upon the stiffness of the part. If a part is loaded with a vibration load with a frequency close to, or equal to, one of its eigenfrequencies, a potential danger of part damage exists.

In automotive components, it is often desirable to have the lowest eigenfrequency of any part to be above the normal operating frequencies of the vehicle. Therefore, although a part may be stiff enough to meet static loading requirements, it may require additional stiffness to increase the eigenfrequencies.

Finite element analysis can be used to predict the eigenfrequencies of the part as well as the vibration modes shape for each of the eigenfrequencies. This type of analysis is called modal analysis. Modal analysis results are very sensitive to the type of loads, restraints and their locations on the part. Often it is possible to significantly change the vibration behaviour of a plastic part by redesigning the way it is mounted or restrained.

2.2.6 Safety factors

The use of safety factors in engineering design is common practice with almost all types of material. Plastics are no exception to this rule. Conservative assumptions should be made when possible and worst case loads should be considered. It is the responsibility of the design engineer to anticipate that products will not always be manufactured or used as intended or planned. In some cases, product failure is acceptable under unusual loading, or for an occasional poorly manufactured part. However, there are many cases in which safety factors must be considered.

There are numerous reasons why a product can have less than its originally intended properties. Some of these reasons are beyond the control of the designer and include:

- Exposure to chemicals which does not normally occur
- Moulding issues such as insufficient drying or excessive heating of the resin
- Tool wear resulting in dimensional changes of the part

- The part is used at temperatures above the expected maximum.
- The part is used in a manner other than what it was designed for.
- The part is assembled poorly or 'forced', incurring a pre-load
- Excessive moulded-in stresses resulting from high moulding pressures, too small gates and too low tool temperatures.

A safety factor is typically decided upon based on prior experience with similar designs. In general, the greater the potential damage from failure, the greater the factor of safety that should be used. In many industries, safety codes and test procedures exist, which give standards and recommendations for safety factors.

2.3 Increasing part stiffness

Features like ribs and V-grooves can be used efficiently to improve the stiffness and the load bearing possibilities of a part. This is accomplished by locating as much material as possible as far as possible from the neutral axis of the part. This increases the moment of inertia. As can be seen from Example 2 in Section 2.2.2 (d), the moment of inertia increases to the third power of the distance of the material to the neutral axis, and only linearly with the distance along the neutral axis. This is a principle that has to be kept in mind when designing stiffeners into a part.

2.3.1 Ribs

Ribs are the most commonly used stiffeners. Processing and tooling determine certain requirements for the shape and the thickness of the ribs, (see Chapter 8). For a part under bending, the ribs should run perpendicular to the bending moment. For parts under torsion, ribs most efficiently increase the stiffness if they are placed diagonally. For pure stiffness reasons, it is important to note that high ribs are more efficient than thick ribs.

2.3.2 V-grooves

V-grooves, (■ FIGURE 7), are often incorporated into parts where significant increases in stiffness are necessary, and other requirements permit their use. V-grooves are very efficient stiffeners because they do not use large amounts of additional material and they do not require additional cooling time. However, V-grooves often cannot be used because they provide an uneven top and bottom surface.

■ FIGURE 7

V-grooved structure

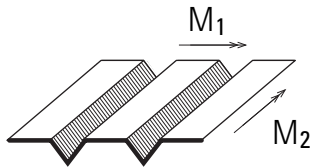

■ FIGURE 8

Corrugated structure

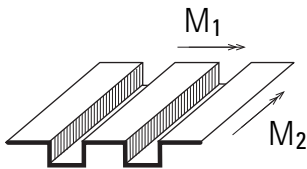

As with ribs, V-grooves provide additional stiffness by increasing the average distance of material from the neutral axis of the part. For bending problems, V-grooves should be oriented in the direction perpendicular to the bending moment. V-grooves can decrease the bending stiffness when the bending moment is directed along the V-groove. The V-grooves given in ■ FIGURE 7 are efficient for bending moment M_1 , but inefficient for bending moment M_2 .

2.3.3 Corrugation

Corrugation is similar to the V-groove. It also does not use large amounts of additional material and does not require additional cooling time, but, like the V-groove, often cannot be used since it provides an uneven top and bottom surface. A stiffness increase is only achieved for a bending moment perpendicular to the corrugated axis, and can even be reduced for bending moments along that axis.

The corrugation shown in ■ FIGURE 8 is efficient for bending moment M_1 but inefficient for bending moment M_2 .

Note that for V-grooves and corrugated structures, when larger loads are applied, the stiffness can decrease due to the fact that the profile becomes flatter, and hence the moment of inertia becomes smaller. This can be avoided by putting ribs perpendicular on the axis of the corrugated structure.

2.4 Optimization of stiffness

Before an optimization study is started, the parameter that must be minimized must be determined. In most cases this is either part weight or part costs.

2.4.1 Optimization for stiffness to weight ratio

2.4.1.1 Material selection

When designing for an optimum stiffness to weight ratio, for example aircraft components, often a material with a high Young's modulus and yield strength is recommended. Of course the material also has to meet other requirements like the moulding capability, aesthetics, environmental resistance, and appropriate regulatory or standard requirements. Often glass-fibre reinforced materials are selected, together with materials such as Ultem® polyetherimide resin because of their strength and stiffness.

Another important factor for part weight optimization is density. It is often recommended to choose a material with the highest ratio of elastic modulus to density, which meets all the other requirements. A material with a very good stiffness to density ratio is engineering structural foam. Furthermore, the larger wall thickness at equivalent weight is a plus, since it gives a greater moment of inertia for bending loads.

Note that when a glass fibre-reinforced material is used, the stiffness is mainly increased in the direction, (orientation), of the glass fibres. This means that the design engineer must ensure that in the critical areas the fibres are aligned in the right direction in order to optimize the performance of the glass-filled material. The direction of the glass fibres is dependent on the flow direction of the material during injection moulding. The gating of the part therefore has to be designed in such a way that the increased material stiffness due to glass fibre reinforcement is used.

2.4.1.2 Geometric considerations

It is not possible to give a general rule of how the geometry of a part should be optimized, since it heavily depends on the type of loading and other factors. Furthermore, design limitations imposed by the material and the process will limit the designer's freedom. In general, it can be stated that material should be added where it most effectively enhances the stiffness of the part. Finite element analysis techniques are particularly useful for geometrical part weight optimization. Localized areas of high and low stress can be easily identified and redesigned. Material situated in an area of low stress does not contribute significantly to the part stiffness. Areas of high stress are areas where also large strains occur which induce large deflections. An optimum part design for stiffness, and strength, would result in the most uniform stress distribution possible, subject to all other limitations.

2.4.2 Optimization for stiffness to cost ratio

Designing for an optimum stiffness to cost ratio is often critical in applications such as material handling pallets and building and construction components. The situation is very similar to designing for optimum stiffness to weight, except that the final part weight must be

multiplied by the cost per kg. of the material. All of the techniques mentioned above still apply.

When designing an application for which the cost is critical, all costs should be considered, including material costs, processing costs, tooling costs, secondary costs and inventory costs.

EXAMPLE 3

Comparison of a ribbed, V-grooved and corrugated structure.

This example shows how different levels of stiffness can be reached using the same amount of material. Furthermore, differences between hand calculations, linear finite element calculations, and geometrically nonlinear finite element calculations are shown and discussed.

Suppose that a beam, supported on two sides as shown in ■ FIGURE 9 is loaded with a force in the middle. The length is assumed to be 800 mm. Suppose that for the cross-sectional area a rectangle with a width of 20 mm and a height of 10 mm is available.

Three possible cross-sections are shown in ■ FIGURE 10, each of them using the same amount of material. A V-groove, a

ribbed and a corrugated structure have been chosen. ■ TABLE I summarizes some geometrical properties of the three different sections. As can be seen, for the load on the beam, which results in bending moment around the y-axis, the corrugated beam has the highest stiffness.

For the beams with the three different cross-sections, a hand calculation and a linear finite element simulation using shell elements have been performed. For the finite element simulation, the mid-lines of the cross-sections are modelled and the thickness is superposed on that. The results are presented in ■ TABLE II. The formula for the hand calculation to calculate the deflection f is:

$$f = F\ell^3 / (48YI)$$

where F is the force, ℓ the length of the beam, Y the Young's modulus of the material and I the moment of inertia.

■ FIGURE 9

The restraint and the loads on the beam

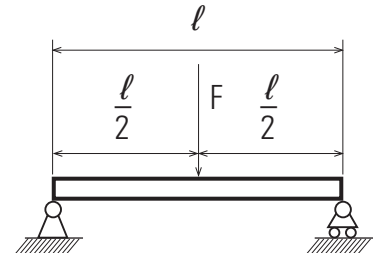

■ FIGURE 10

The cross-sections of the beam

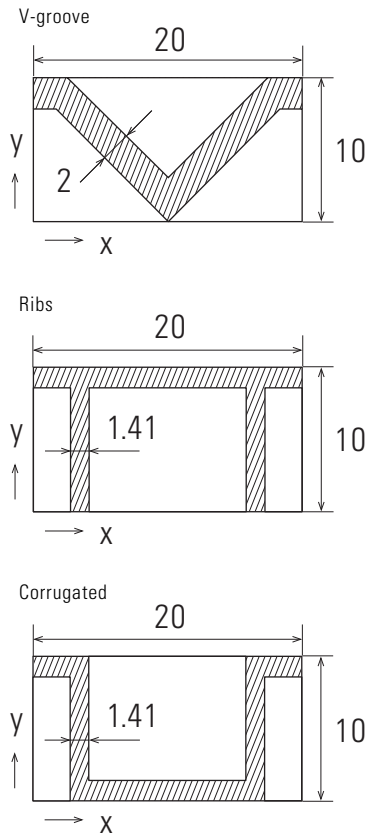

■ TABLE I

Some geometrical properties of the cross-section

Quantity	V-groove	Ribs	Corrugated
I (mm ⁴)	348.6	480.6	668.0
x-coord c.g. (mm)	10	10	10
y-coord c.g. (mm)	5.896	6.983	4.403
Area (mm ²)	52.57	52.57	52.57

■ TABLE II

Hand calculation and linear finite element results

Deflection at 10N	V-groove	Ribs	Corrugated
Hand calc. (mm)	139	101	72.5
Linear f.e.m. (mm)	148	99.6	74.0

■ FIGURE 11

The cross-sections of the beams in a finite element analysis with shell elements

V-groove

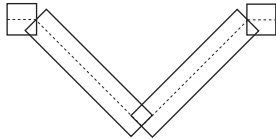

Ribs

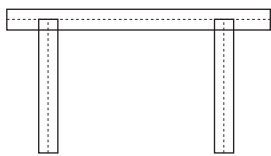

Corrugated

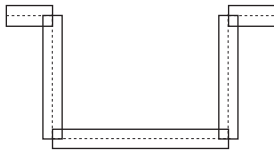

The deviations between the results from the hand calculation and those from the linear finite element method, (f.e.m.), are due to the fact that for f.e.m. I is calculated from the thickness superposed on the mid-line of the cross-section, (■ FIGURE 11). This means that the stiffness is underestimated by the f.e.m. for the V-groove and to a lesser extent for the corrugated section. The stiffness is slightly over-estimated for the ribs.

In order to study the effect of a linear f.e.m. calculation versus a nonlinear f.e.m. calculation, geometrically nonlinear f.e.m. simulations have also been performed. The results are shown in ■ FIGURE 12. It can be seen that for larger deflections, there is a considerable difference between the linear and the nonlinear simulation.

■ FIGURE 12

The difference between a linear and a non-linear finite element analysis

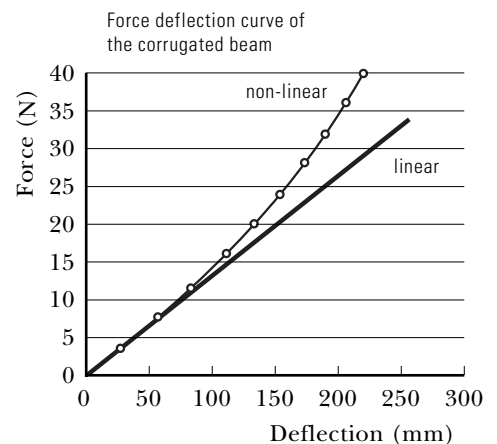
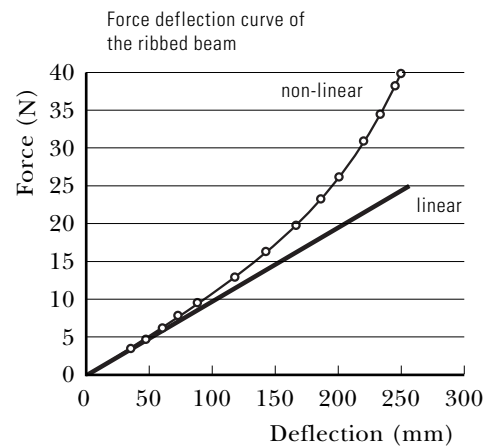
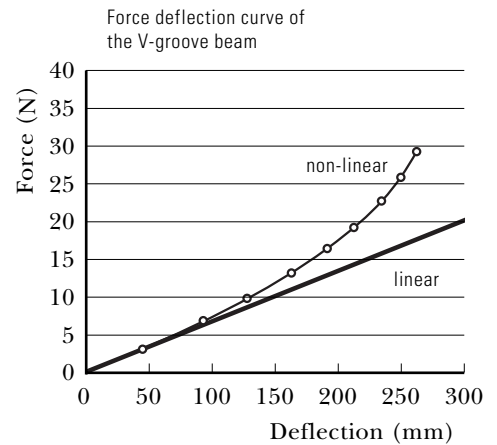

3

Design for strength

3.1 Introduction

The strength of a part is defined as the maximum load that can be applied to a part without causing part failure under given conditions. In order to be able to determine the strength of a part, first failure has to be defined. The right definition of failure depends on the application. In some cases a part has failed if it shows a certain amount of permanent deformation, while in other cases this can be allowed and failure is defined as breakage of the part. In other more critical applications, failure must be defined as the load at which the first crack occurs in the material.

This chapter explains how to obtain strength measures from standard material data. Different failure definitions are discussed and ways of determining the strength of a part are presented. Furthermore, some general guidelines to design for strength are given.

3.2 Material strength

From a materials point of view, strength is a stress/strain related property inherent in the material. There are many different stress/strain issues which can relate to strength and which must be understood in order to design for strength. A variety of standard tests is available to study the stress/strain behaviour of a material under various conditions. In general, the tensile test provides the most useful information for engineering design. Other standard tests that are performed to obtain strength data are flexural testing, shear testing and compression testing.

Two typical stress/strain curves obtained from a tensile test are shown in **FIGURE 13**. One curve is from an unfilled thermoplastic and the other curve is from a filled thermoplastic. For the unfilled thermoplastic, for small strains the stress increases proportionally with the strain however

soon nonlinearities occur; a close observation of the stress/strain curve shows that actually a proportional part does not exist. For larger strains, yielding occurs and the maximum stress is reached. If the strain is increased further, necking will occur and the neck will propagate through the structure until the material fails.

For a glass-filled thermoplastic, the stress increases faster with an increasing strain; a glass-filled thermoplastic has a higher Young's or elastic modulus. For larger strains, nonlinearities occur and the part fails in brittle mode when the failure strain is reached. The following strength measurements can be obtained from these curves:

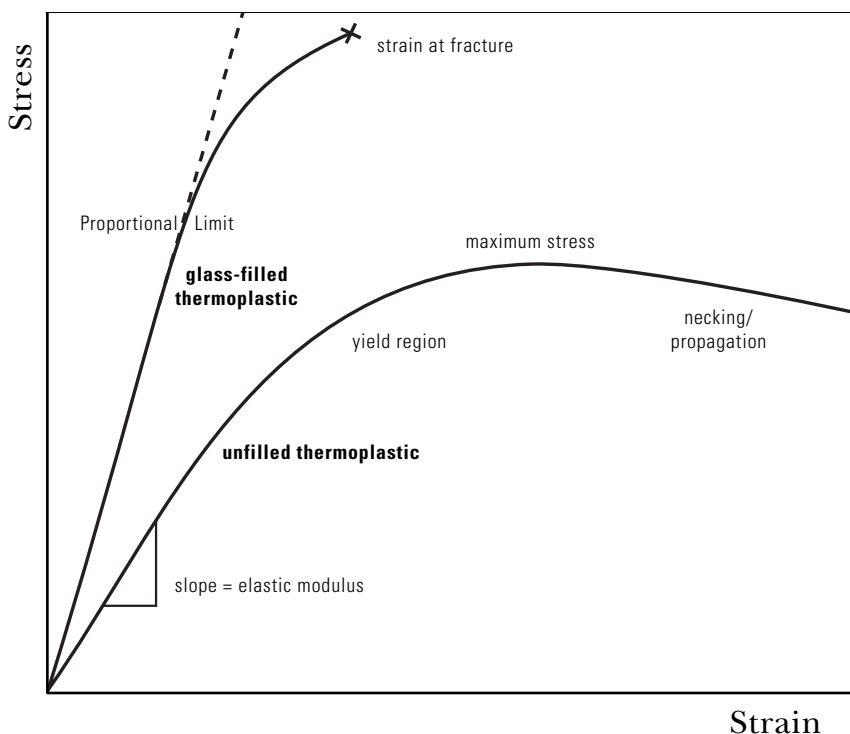

■ FIGURE 13
Typical stress-strain
curves for thermoplastics

3.2.1 Ultimate strength

The ultimate strength, (tensile, flexural, compressive, or shear), of a material is the maximum stress level in a sample prior to failure. The ultimate tensile strength of a material is the maximum load per unit area that the material will bear before failure. This value can be obtained from the maximum stress value on the stress/strain curve (see ■ FIGURE 13). Simple formulae are often used to obtain strength values from the load-displacement output of non-tensile type tests. Ultimate strength is a function of temperature and strain rate.

3.2.2 Yield strength

The classical definition of the yield strength of a material is the stress level which will cause a small amount of permanent deformation, (standard is 0.2 % strain). This definition originates from the steel industry, but it also applies to plastics. However, the yield point of thermoplastics is difficult to determine because of their viscoelastic nature. The yield point for classical materials such as metals can easily be determined and tested by loading the sample to a point slightly beyond the proportional limit, (linear portion of the stress/strain curve), and then unloading it and measuring the deflection. Therefore, with some experience it is easy to predict. When plastic materials are tested in a similar manner, what originally appears to be permanent deformation can be recovered slowly. The amount of recovery is dependent on the temperature and the rate at which the sample is tested. The yield point of a thermoplastic cannot be determined from a stress/strain curve. For this reason, thermoplastic yield points are typically estimated or shown as a yield range, (see ■ FIGURE 13).

3.2.3 Strain to failure

Another material property which is related to strength is the percentage of strain at which the material fails, (see ■ FIGURE 13). This can easily be obtained from the stress/strain curve. As with many other plastic material properties, the strain to failure is highly dependent on the temperature, the strain rate and the ductility of the material. When the stress/strain curves of the glass-filled material and the unfilled material are compared, the strain to failure of the glass-filled material is much smaller than that of the unfilled material. This is due to the

fact that, for the glass-filled material brittle failure occurs, and for the unfilled material ductile failure occurs.

3.2.4 Proportional limit

The proportional limit of a material is the point at which the stress/strain curve becomes nonlinear, (see ■ FIGURE 13). Although the proportional limit of a material is often considered to be the same as the yielding point, the two are distinctly different. For many conventional materials like metals, the stress/strain curve is so highly linear that the two values are very close. For plastics, however, the viscoelastic nature of the material can push the yield point of the material well out into the nonlinear region of the stress/strain curve. Also the proportional limit is heavily temperature- and strain rate-dependent. Note that, strictly speaking, due to the viscoelastic nature of plastics, a proportional part of the stress/strain curve does not exist for these materials.

3.2.5 Material toughness

Material toughness is a useful property for comparing material strengths. As with most material properties, it is highly dependent on temperature and strain rate. Toughness is the energy absorbed by the material. The area under the stress/strain curve is equal to the absorbed energy per unit volume.

3.2.6 Other measures

Other measures that are equally important for strength, but are not directly related to the stress/strain curve, are impact strength and fatigue strength. For impact strength, readers are referred to Chapter 5, 'Design for impact performance'.

The fatigue strength of a material can be measured in a number of ways. Typically, it is expressed as the number of cycles to failure of a standard test specimen when subjected to tensile or flexural cyclic loading, in accordance with test standards. It can also be expressed as the stress which a material can withstand up to a given number of cycles without failing.

3.3 Effects of various factors on the strength measures

As mentioned earlier, temperature and strain rate heavily influence the strength measures of materials. In addition, the use of glass fibres alters the strength of materials. ■ TABLE III summarizes the effects of temperature increase, strain rate increase and addition of glass fillers on the strength measures.

3.3.1 Other factors

(a) Chemicals

The chemical compatibility of engineering thermoplastics is a complex phenomenon dependent on the material, type of chemical, mode and

■ TABLE III

Effect of temperature, strain rate and glass fibres on the strength of materials

	Temperature ↗	Strain rate ↗	Add glass fillers
Ultimate strength	↘	↗	↗
Yield strength	↘	↗	↗
Strain to fracture	↗	↘	↘
Proportional limit	↘	↗	↗ stress, ↘ strain
Material toughness	*1	*2	↘

*1 A measure of material toughness is the area under the stress/strain curve. An increase in temperature decreases the maximum strength. This effect will increase toughness. But an increase of temperature also decreases the strain to failure which will decrease the toughness. Hence, the effect of a temperature increase on material toughness depends on the balance of the two factors described.

*2 The influence on material toughness of an increased strain rate also depends on the balance of two different effects. Material toughness is increased at larger strain rates due to the increased ultimate strength but, on the other hand, it is decreased due to the lower strain to failure.

duration of exposure, temperature, and levels and state of stress present during exposure. Different types of chemicals can embrittle a thermoplastic material or can cause it to become softened.

However, it is not possible to classify the general effect of chemicals on materials. For more specific information readers are invited to contact their GE Plastics' representative.

(b) Moisture

Moisture can significantly affect the strength of engineering thermoplastics, much in the same way as chemicals. The hydrolytic stability of engineering thermoplastics is a complex issue dependent upon material type, mode and duration of exposure, temperature, and stress level and stress states in the material. Some materials like Noryl® PPO® resin have an excellent hydrolytic stability, while others, such as Lexan® polycarbonate resin, can have hydrolytic stability problems at elevated temperatures. GE Plastics' representatives can supply more specific information.

(c) Processing conditions

Processing conditions can have a significant effect on the strength of a material in the final product. Moisture, small gate sizes, long residence times, (material at melt temperature in the barrel of the machine), sharp corners or wall transitions, or excessive use of regrind can all cause degradation of the polymer. Effectively this means that the average length of the molecular chains which comprise the material is reduced. This can embrittle the material or cause it to have a reduced modulus, yield strength or ultimate strength.

Other moulding parameters such as low tool temperatures or high injection pressures can cause a significant increase in the levels of moulded-in stresses. These, in turn, add to the stresses induced in the part by the load and hence decrease the load bearing capabilities of the part.

Another important aspect of processing is the occurrence and the location of weld lines. The material strength on a weld line is significantly lower. This means that it is important to avoid weld lines in areas where large stresses are expected due to the applied loads.

3.4 Part Strength

The strength of a plastic part can have different meanings depending on the part. There are many different concepts

of what part strength really means.

In some cases, stress limits like yield strength and ultimate strength are most important, while in other cases yield strain and ultimate strain are important.

The meaning of the term strength of a part will depend upon the type of application, the function of the part, loading conditions, restraint conditions, and the performance of competitive or comparable parts. In this section three measures of part strength will be discussed: ultimate part strength, part yield strength and part toughness. The material parameters that are important for part strength depend on both the measure of part strength and on the type of loading. Two types of loading will be distinguished: load (or force) controlled applications and deflection controlled applications. A load controlled application is defined as an application which must bear a load of a certain magnitude. A deflection controlled application is an application to which a deflection of a certain magnitude is applied.

3.4.1 Ultimate part strength

Consider the force deflection curve as depicted in ■ FIGURE 14. Suppose this curve is the result of a test on an actual plastic part. When the part is loaded to point A, the part breaks. The force and deflection level at which the part breaks can be defined as the strength of the part. The maximum force level is usually referred to as the ultimate strength, while the maximum deflection level is referred to as the ultimate deflection.

This concept of strength is common in engineering design, especially when factors of safety and worst case loadings are considered.

An example of this type of strength concept on a load controlled application is the design of load bearing aircraft components. In these designs, loads of many times the expected load are considered in order to assure safety. Other part strength concepts like permanent deformations are not of concern. In this case, the ultimate part strength is dependent on the ultimate strength of the material and on the geometry of the part.

Another example is a flexible bearing cover in a car. In this case, the application is deflection controlled and it is possible that an extreme loading condition on the bearing could produce a deflection far beyond the normal operating range, which can cause the part to rupture. The ultimate strength of a part is dependent on the strain to failure of the material and the geometry.

In summary, when ultimate strength is considered, for load controlled applications the ultimate strength is the governing material parameter, while for deflection controlled applications the strain to failure is the governing material parameter. Materials should be selected accordingly.

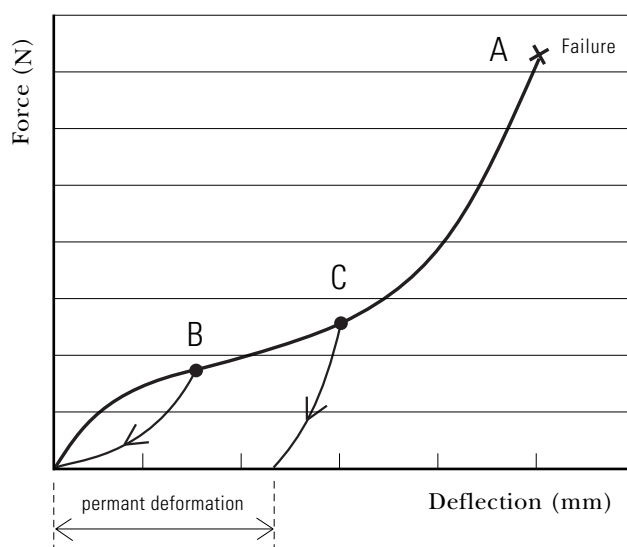

■ FIGURE 14
Sample load-deflection curve of a part

3.4.2 Part yield strength

Suppose that the part, (■ FIGURE 14) is loaded to point B and then unloaded. After a certain time, the part regains its original shape. If the part is loaded further, (for example to point C) and then unloaded, it does not retain its original shape and a permanent deformation will occur.

If at a certain level of permanent deformation the part ceases to be useful and must be replaced, then this is again a new strength criterion which is referred to as the part yield strength. An example of a load controlled application is a thermoplastic spring. Permanent deformation of the spring usually makes it non-functional. In this case, the part strength depends on both the yield strength of the material and on the geometry of the part. Another example is a plastic snap-fit. A snap-fit is a deflection controlled feature where over-extension can cause permanent deflection. This can make the snap-fit useless if it cannot return to engage the stop. In this case, the part strength depends on both the yield stress, (or yield strain), of the material and on the geometry of the part.

A refinement of this failure criterion could be the allowance of a certain amount of permanent deformation. If this is the case, strain recovery plays an important role. When a material is loaded and afterwards unloaded, (for example up to point C in ■ FIGURE 14), the permanent strain will partly disappear in time.

In order to acquire material data, a laboratory test was developed. Tensile specimens were loaded to various strain levels at a rate of 10%/s and then rapidly unloaded, while the strain recovery was monitored. Since the rate of recovery was very small after 10 minutes, the percent recovery, which is defined as the ratio between the residual strain and the applied strain, was plotted after this time as a function of the applied strain. The results are depicted in ■ FIGURE 15. As an example, a design rule of 90% recovery is shown in this Figure. It can be seen that in the case of PC a maximum strain of approximately 9.3% will be allowed, compared to approximately 5.8% for PC-PBT.

3.4.3 Part toughness

Part toughness is often considered to be a good measure of the strength of the part, and depends on material toughness and geometry. It is measured by calculating the area under the load-deflection curve from initial load to part failure. The toughness of a part is an issue for both load and deflection controlled applications, and it is a measure of the amount of energy that a part can absorb.

3.5 Improving the part strength

Once the strength criterion is decided, the strength of a part can be improved. This can be done by selecting the right material and/or by optimizing the part geometry.

3.5.1 Material choice

Based on the strength criterion and the loading type of the application, ■ TABLE IV can be used to decide which material parameter should be increased in order to improve the strength of the part. Based on this information the optimal material can be selected.

■ FIGURE 15

Strain recovery

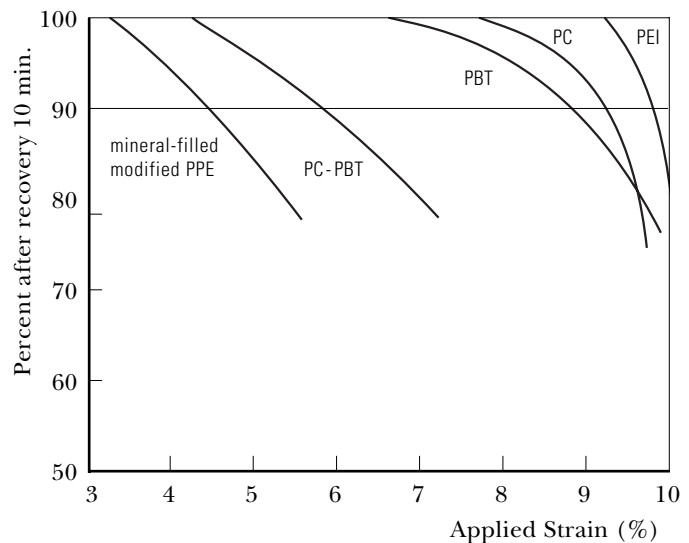

■ TABLE IV

Governing material properties dependent on failure criterion and load type

	ultimated strength	part yield strength		part toughness
		no permanent deformation allowed	some permanent deformation allowed	
load controlled	ultimate material strength	yield stress	maximum strain according to ■ FIGURE 15	material toughness
deflection controlled	strain to failure	strain at yield	maximum strain according to ■ FIGURE 15	material toughness

3.5.2 Geometry optimization

Since the strength of a part depends on many factors, like loads and restraint conditions, it is very difficult to give some general guidelines on how to change a design in order to improve the strength of a part. However, some general remarks can be made dependent on the type of loading on the part. Of course when a design is modified to improve the strength, the design rules that are summarized in the following section have to be respected.

For load controlled applications, the amount of load that has to be carried by the part is known. In the material this load will be transformed to stresses. Areas of large stresses have to be identified and material should be added to the appropriate areas. The goal is to have the load carried by a maximum amount of material. This will decrease the occurring stress levels.

For deflection controlled applications the situation is different. In this case, a certain deflection is prescribed to the part and this results in a given strain in the material. The strength can be increased by removing material in the areas where the largest strains occur. This will significantly decrease the stiffness of the part, so it must be verified if this is allowed.

For load controlled applications the area of maximum stresses and for deflection controlled applications the area of maximum strains have to be identified. In general, hand calculations are not sufficient here, since the stress and strain levels are usually far beyond the point at which the linear calculations are valid. Even the results of detailed finite element analyses have to be interpreted with care. The reason for this is that the accuracy of especially the stresses and the strains is dependent on the type of element used and on the mesh density. This means that the accuracy of the stress and strain levels is not always as high as desired. However, finite element analysis is very well-suited to identifying areas of the largest stresses and to comparing the effect of different possible design changes.

3.6 Design considerations

Some general guidelines for design for strength are as follows:

(a) Avoid stress concentrators

Stress concentrators can significantly reduce the strength of a part and should be avoided. These include sharp notches, or internal corners, sharply angled wall intersections, large wall thickness transitions and surface interruptions such as holes and inserts.

(b) Avoid uncontrollable loading situations

Examples include pipe threads where the designer can have no control over how much it is tightened, causing hoop stress.

(c) Design for compressive stress

As with many materials, unfilled plastic materials tend to be stronger in compression than in tension, as long as buckling does not become critical.

(d) In tension, design for a uniform cross-sectional area

In a plastic part which is primarily in tension, a uniform cross-sectional area should be used to obtain a more uniform stress distribution.

(e) In bending, design for moment of inertia

In a plastic part which is primarily subjected to flexural loading, the moment of inertia is critical in determining the load bearing capability. For maximum load bearing strength, material should be located as far away from the neutral axis as possible. For maximum deflection without yield, material should be concentrated along the neutral axis.

(f) Consider processing aspects

Processing can be critical for the strength of a part. Recommendations include:

- Weld lines should be avoided or located in non-critical areas.
- The frozen-in stresses should be as low as possible.
- For fibre-reinforced plastics, the difference in strength in the flow and the cross-flow direction should be considered

(g) Use safety factors

As with all materials, it is impossible to control all aspects of production and use. For this reason, conservative estimates and risk dependent safety factors should be applied when appropriate.

(h) Consider worst case

In addition to analyzing the expected use for a proposed part, a worst case scenario should also be studied.

4

Design for behavior over time

4.1 Introduction

When discussing time related behaviour, two types of phenomena should be considered. Static time dependent phenomena, such as creep, are caused by a single long-term loading of an application. Dynamic time dependent phenomena, such as fatigue, are produced by cyclic loading of an application. Both types of behaviour are heavily influenced by material choice, operating environment and component design.

The biggest problem experienced when attempting to predict long-term loading effects, is the availability of data specific to an application; most data are based upon standard tests performed upon material specimens. However, this information can be used to give an indication of the performance of a certain design and can be verified by actual physical testing of the thermoplastic components for the required performance.

4.2 Static time dependent phenomena

Traditional structural calculations centre around short-term material data in which the material exhibits perfectly elastic behaviour. However, another important property exhibited by thermoplastics is that of viscoelasticity. This is the simultaneous demonstration of both viscous flow and elastic deformation under an applied load over a long time period. Short-term stress/strain behaviour usually occurs within less than an hour of the load being applied and is often considered instantaneous. Viscoelastic behaviour, however, may continue throughout the working life of a component, often over a period of years.

4.2.1 Creep

Under the action of a constant stress, (load), a viscoelastic material undergoes a time dependent increase in strain called creep or cold-flow. Creep is therefore the result of increasing strain over time under a constant load. The creep rate for any material is dependent upon applied stress, temperature and time.

Creep behaviour is initially examined using plots of strain as a function of time, over a range of loads at a given temperature. Measurement may be taken in the tensile, flexural or compressive mode. In the tensile mode, a test specimen is subjected to a constant tensile stress and the change in length is measured as a function of time. The resultant stress/strain/time creep data are normally presented as curves of strain versus log time. Point A in

■ FIGURE 16 illustrates the initial

deformation due to the applied load on a specimen. Up to this point, the response is elastic in nature and therefore the specimen will fully recover after the load is removed. However, continued application of the load will result in a gradual increase in deformation over time to point B; in other words, it 'creeps'. In the flexural and compressive modes, the specimen is subjected to either a constant bending or compressive load and the deflection is measured as a function of time.

The data may also be presented in other forms to suit particular requirements. Sections taken through the creep curves at constant times produce isochronous stress/strain curves, whilst isometric stress versus log time can be derived from constant strain.

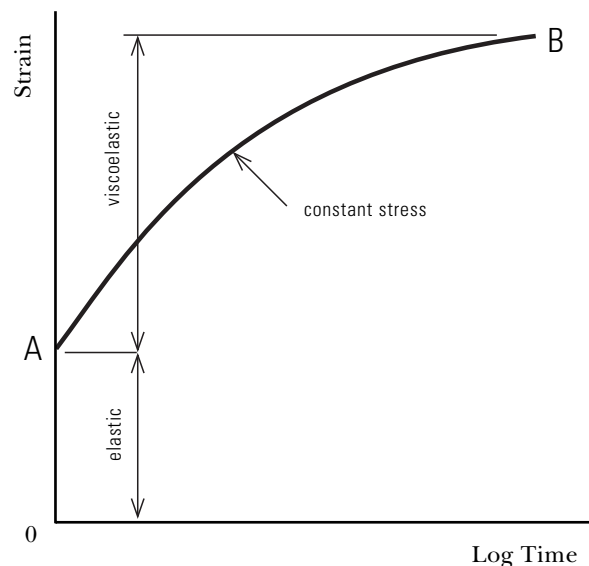

■ FIGURE 16
Typical creep behaviour of an amorphous thermoplastic, assuming no plastic deformation

4.2.1.1 Creep recovery

If the long-term process of creep is interrupted by removing the load, an immediate but partial elastic recovery in the deformation of the specimen can be seen, as illustrated in ■ FIGURE 17 from point B to point C. This represents the release of energy stored elastically by the material when it was first deformed to point A.

As time progresses, recovery continues; in fact, the shape of the curve from point B is almost an inverted copy of the shape up to point B. The amount of recovery depends upon the type of material, the applied stress, the temperature and the duration of loading. In some cases, there will eventually be total recovery of the deformation, as

illustrated by point D in ■ FIGURE 17, whilst in others, a significant amount of permanent plastic deformation will occur, as illustrated by point E.

4.2.1.2 Creep failure modes

There are two failure modes encountered under the action of creep.

(a) Excessive deformation

When the deformation of a component exceeds the allowable limit for that application.

(b) Creep Rupture

This may result in either a brittle or ductile fracture of the component. Measurement of creep rupture is performed in the same manner as

creep, except that higher stresses are used and time measured to failure. Results are usually presented as log stress versus log time to failure, as in ■ FIGURE 18.

4.2.1.3 Apparent Modulus

Though creep and creep rupture data give an indication of the long-term behaviour of a material, for practical design purposes the corresponding reduction in modulus over time is of greater value. If a calculation is performed on a component subjected to a continuous load, and short-term moduli such as E, (modulus of elasticity), or G, (shear modulus), are used, the result is likely to be misleading since neither E nor G reflect the effects of

■ FIGURE 17
Typical creep recovery diagram of an amorphous thermoplastic, assuming no plastic deformation

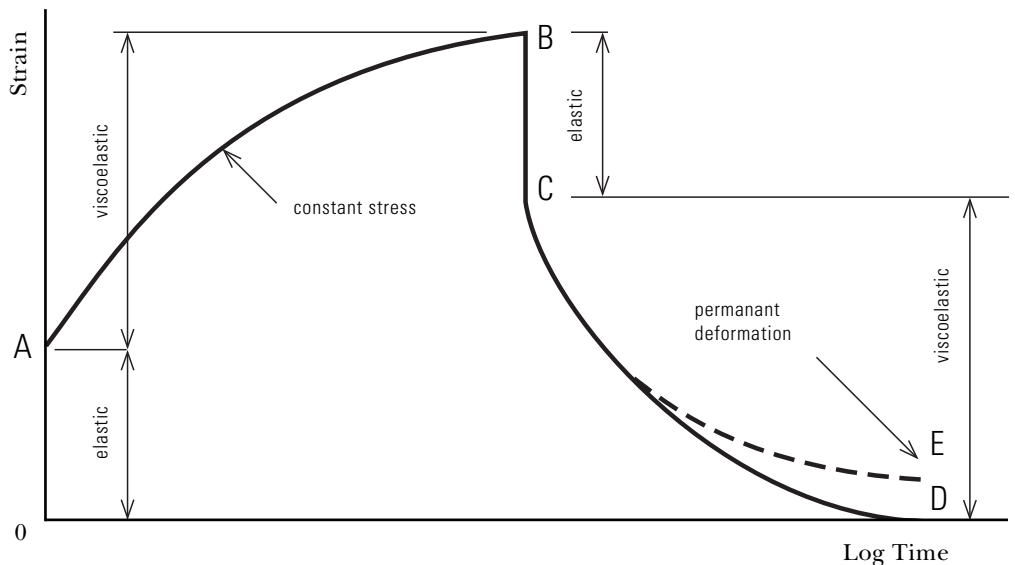

■ FIGURE 18
Typical creep rupture data, with one cycle projection

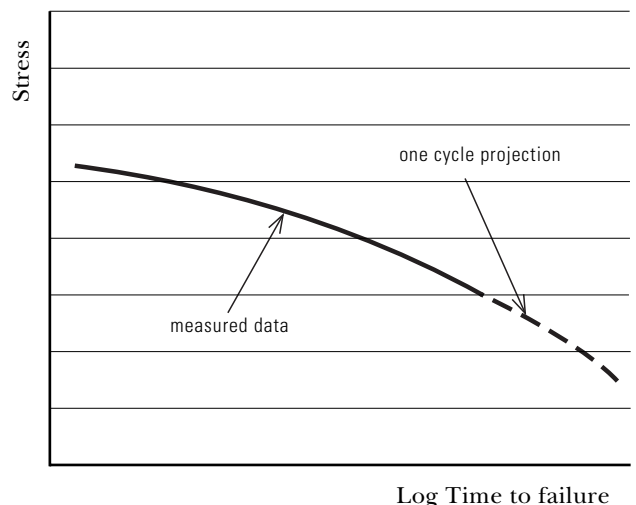

creep. When the stress level and temperature are known and creep curves are available at the given temperature, an apparent or creep modulus, E_{app} , may be calculated using the creep curves;

$$E_{app} = \frac{\sigma}{\epsilon_c}$$

Where;

σ is the calculated stress level.

ϵ_c is the strain from the creep curve at a given temperature and time.

The value E_{app} can then be substituted for E , or the like, in standard structural design equations. Creep modulus curves or log creep versus log time at either constant stress or strain are usually derived from creep data, see ■ FIGURE 19.

4.2.2 Stress relaxation

Unlike creep where the strain increases over time, stress relaxation is the reduction in stress in a component over time under a constant strain. The area where stress relaxation is of greatest impact is in component assembly. This includes threaded assembly, inserts, press-fits and snap-fits, although any component undergoing long-term deformation may be affected to some degree.

Initially, the material is subjected to a strain ϵ_1 which is maintained for a long period, that is to ϵ_2 , (see ■ FIGURE 20). The immediate response of the material when the strain is applied is an increase in stress from zero to σ_1 . This value is temperature dependent and tends to decrease as a function of time, that is to σ_2 , (see ■ FIGURE 21).

Stress relaxation data can be generated by applying a fixed strain to a sample and measuring the gradual decay of stress over time. The resultant data can then be used to generate stress relaxation curves which are very similar to isometric strain curves.

Stress relaxation data can be used to generate a relaxation modulus, similar to the creep modulus.

However, relaxation data are not as commonly available as creep data. In such instances, however, it is possible to approximate the decrease in load due to stress relaxation by using the creep modulus, E_{app} .

The use of standard moduli, (E or G), in structural calculations, is inappropriate for the long-term structural performance of assembled components as it does not reflect the effects of stress relaxation.

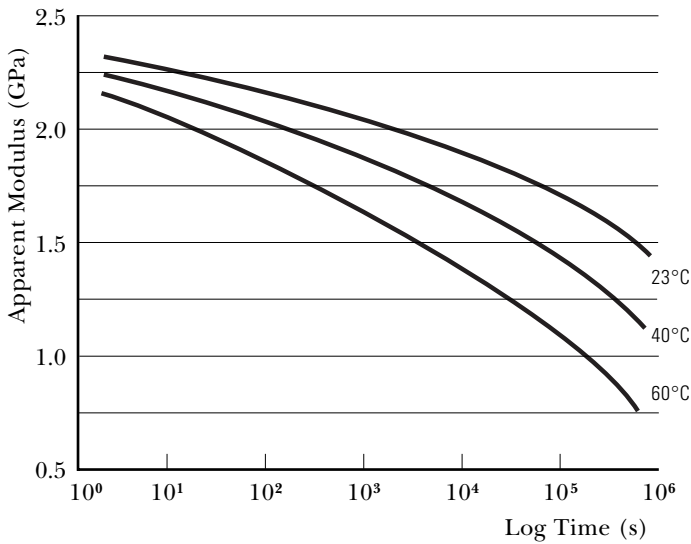

■ FIGURE 19
Typical Creep Modulus curve of Apparent Modulus versus Log Time for a given material at different temperatures

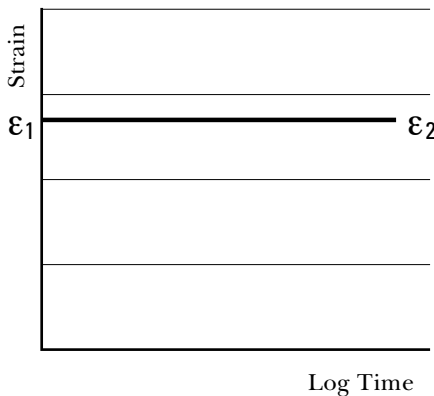

■ FIGURE 20
Graph illustrating constant strain over time

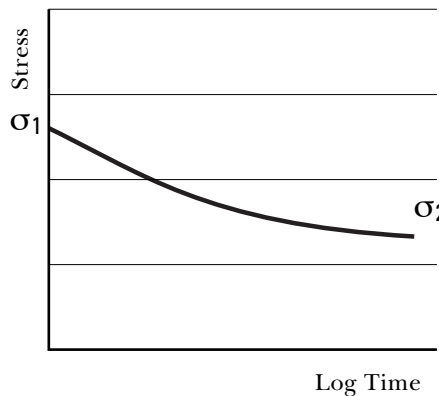

■ FIGURE 21
Graph illustrating stress relaxation over time for constant strain

4.2.3 Design considerations

Creep is often a critical concern when designing a structural part in thermo-plastics. Although data exist for specific times, stress levels and temperatures, it is often difficult for engineers to translate this data into structural analyses relevant to their application. Since the process of individual testing over long time periods is not feasible, methods of interpolating and extrapolating data from short-term behaviour are necessary.

Several methods for extrapolating time/strain data exist, each with the objective of obtaining the most accurate fit to the actual data, while giving reasonable extrapolation predictions for longer time periods. From work performed within GE Plastics, it was determined that for its materials the best fit for the data appeared to be given by a quadratic function of log time. However, engineering judgement must be used concerning the extent of the extrapolation in time. It is not recommended that the extrapolation exceed more than one unit of logarithmic time and a strain/elongation limit of 20% of the yield or ultimate stress/strength value for the material being analyzed. It should be noted that although amorphous materials give a single curve when interpolating to other temperatures, for semi-crystalline materials two plots are required to create the curve, one above and one below the glass transition temperature (T_g) of the material.

4.3 Dynamic time dependent phenomena

4.3.1 Fatigue

This is the process by which a material is stressed repeatedly or in some defined cyclical manner. The magnitude of the loading is usually of such low value that failure would not normally be expected were it applied only once. Additionally, the loading and its frequency of application may vary in value.

Structural components subjected to vibration, components subjected to repeated impacts, reciprocating mechanical components, plastic snap-fit latches and moulded-in plastic hinges are all examples of applications where fatigue can play an important factor. Cyclic loading can result in mechanical deterioration and fracture propagation through the material, leading to ultimate failure.

Fatigue tests are usually conducted under flexural conditions, though tensile and torsional approaches are also possible. A specimen of material is repeatedly subjected to a constant deflection at constant frequency, and the number of cycles to failure is recorded. The procedure is then repeated over a range of deflections. The test data are usually presented as a plot of log stress versus log cycles; this is commonly referred to as a S-N curve.

4.3.1.1 Fatigue and endurance limits

The most important features of an S-N curve are;

- The greater the applied stress or strain, the fewer the cycles a specimen will survive.
- The curve gradually approaches a constant value, known as the fatigue limit, as illustrated in ■ FIGURE 22. Below this value of stress or strain failure is very unlikely. Some materials do not exhibit a fatigue limit and for these materials an endurance limit is specified. This is the value of stress or strain at a stated number of cycles beyond which the specimen will fail, (see ■ FIGURE 23).

■ FIGURE 22

Typical fatigue curve for a material with a fatigue limit

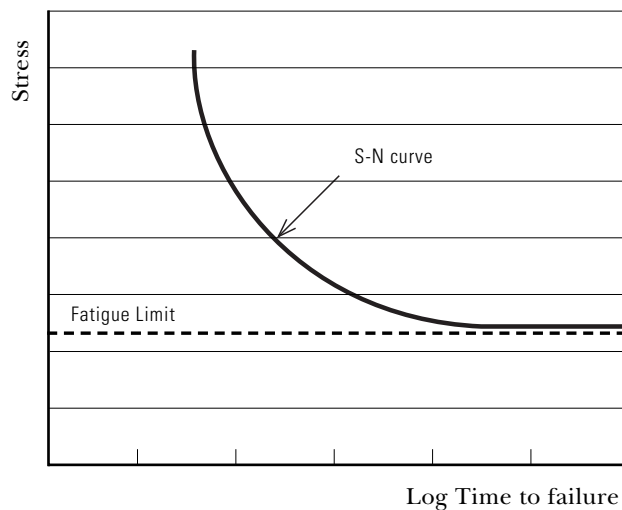

■ FIGURE 23

Typical fatigue curve for a material with an endurance limit

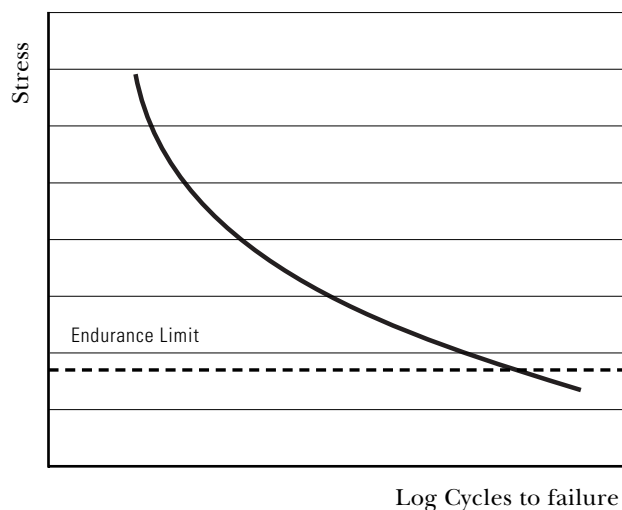

4.3.1.2 Factors affecting fatigue

S-N curves, obtained under laboratory conditions, may be regarded as 'ideal'. However, practical conditions usually necessitate the use of a modified fatigue or endurance limit, as other factors may affect performance. These include:

Type of loading

Results of tests performed under flexure may not be directly applicable to components subjected to axial or torsional loading.

Size of component

A deterioration in fatigue properties is usually experienced with increasing physical dimensions.

Mean stress

Amplitudes about a tensile mean stress reduce fatigue and endurance limits, whereas an increase occurs when the mean stress is compressive.

Loading frequency

At high frequencies, an increase in temperature may be experienced if inadequate provision for heat dissipation exists. This may lead to deterioration in fatigue properties.

Amplitude

The onset of fatigue failure may also be accelerated at low frequency under conditions of high amplitude.

Fatigue testing provides only an indication as to a given plastic material's relative ability to survive fatigue. Therefore, it is essential that tests are performed on actual moulded components under actual end-use operating conditions, in order to determine the true fatigue endurance of that component.

4.3.2 Wear resistance

Wear can be described as the reduction of a bearing surface due to the loss of molecular adhesion as a result of mechanical friction, (see ■ FIGURE 24). There is no apparent consistent relationship between friction and wear; friction may be high and wear low, and vice versa.

4.3.2.1 Types of wear

Adhesive wear

Surface shearing, deformation and removal of material at the points of adhesion.

Abrasive wear

Surfaces of different hardness in contact, with grooves being ploughed in the softer material, the presence of an abrasive medium and erosion abrasion due to particles impacting the surfaces.

Fatigue

Surface fatigue failure as a result of surface or sub-surface stress exceeding the endurance limit of the material.

4.3.2.2 Factors affecting wear

The wear resistance of a thermoplastic is dependent on the environmental conditions of the end-use application. Temperature, surface contamination, (chemicals, grease, etc.), surface structure and contouring, all have an influence on wear resistance. Changes in the wear process occur with the degree of surface roughness of the bearing materials. In the case of plastics, this is strongly dependent on the modulus of elasticity, (E-modulus), of the materials being used.

Optimally moulded surfaces of Valox® PBT resin components have a relative smoothness which makes them ideally suited to low friction, high wear resistance applications over a wide range of operating conditions. In general, Valox resins exhibit very low coefficients of static and dynamic friction against metals and also against similar Valox resins. Other semi-crystalline resins generally exhibit an appropriate wear resistance against metals but invariably may not be suitable for applications where they bear against themselves.

It is important to remember that the operating environment of the end-use application should be taken into consideration when using frictional values for engineering design purposes.

■ FIGURE 24

Microscopic view of surfaces in contact

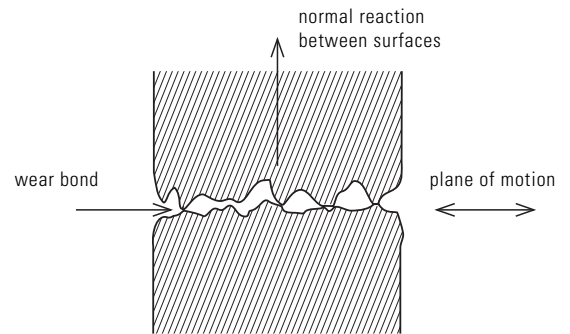

5

Design for impact performance

5.1 Introduction

Impact strength can be described as the ability of a material to withstand an impulsive loading. By definition, any body in motion possesses kinetic energy and, when this motion is stopped, the energy must be dissipated.

There are several factors which determine the ability of a plastic component to absorb impact energy:

- Type of material
- Wall thickness
- Geometric shape of component
- Size of component
- Operating temperature
- Rate of loading
- Stress state induced by loading

For ductile polymers, the load at which yielding occurs in a component is affected by the operating environment as illustrated by the last three factors detailed above. Of even more significance to design is the fact that, under the appropriate circumstances, the impact behaviour of a ductile polymer will undergo a transition from ductile and forgiving in its response, to brittle and catastrophic.

Usually this change in behaviour is described in terms of a transition temperature above which the failure is more ductile in nature, and below which it is more brittle, as illustrated in ■ FIGURE 25. However, both rate of loading and stress state have an effect on this transition temperature.

5.2 Common impact testing methods

A number of tests are commonly used to provide insight into the response of plastics to impact loadings. Two generic types of testing exist, pendulum and falling weight methods. It is important to note that none of these traditional test methods results in real, geometry independent material data which can be used in engineering design calculations.

They can be useful in applications for quality control and initial material comparisons, but even in this latter role different tests will often rank materials in a different order. Typical traces for both ductile and brittle response to an instrumented impact measurement system are illustrated in ■ FIGURE 26.

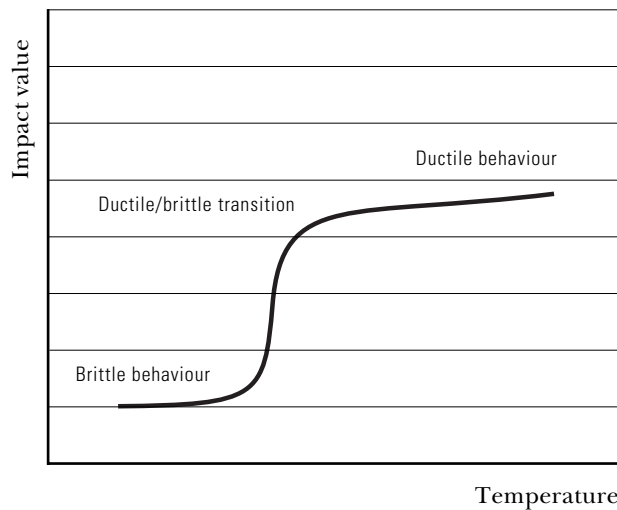

■ FIGURE 25
Graph illustrating effect of temperature upon impact response

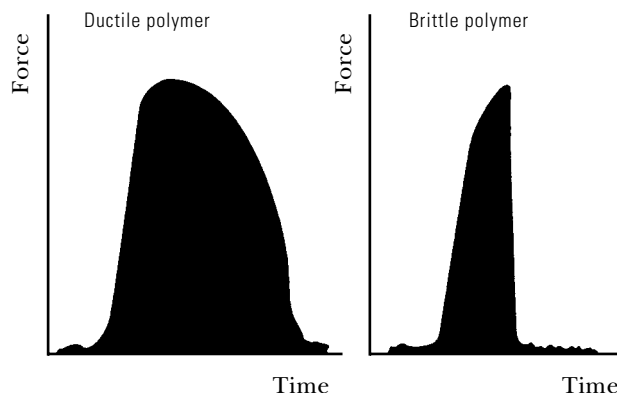

■ FIGURE 26
Typical force/time curves for ductile and brittle material responses, as produced by an instrumented system

 Energie absorbed by specimen

■ FIGURE 27
Illustration of Charpy impact test configuration

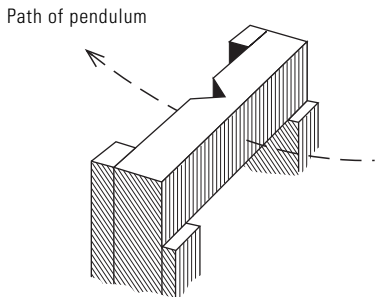

■ FIGURE 28
Illustration of Izod impact test configuration

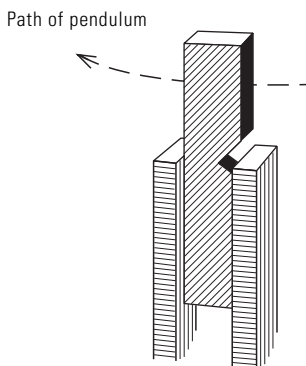

■ FIGURE 29
Illustration of tensile impact test configuration

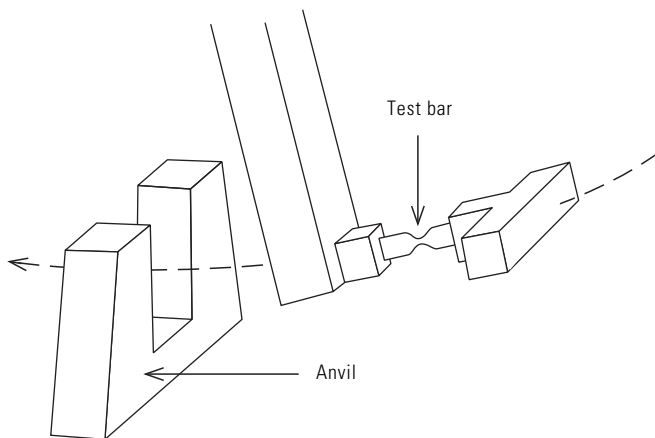

5.2.1 Pendulum methods

In this form of testing, a specimen of material is struck by a pendulum under defined conditions, and the energy required for fracture is measured. It should be noted that the results of these tests are highly dependent upon the geometry of the test specimen and that the results do not define actual material properties.

(a) Charpy impact

In this test, a notched specimen is simply supported. When released, the pendulum strikes the specimen centrally, resulting in fracture. The energy absorbed by the specimen is displayed by a system activated by the motion of the pendulum, (see ■ FIGURE 27).

(b) Izod impact

This is similar to Charpy though differing more in notch geometry and method of specimen support. In this test, the specimen is mounted vertically, impact consequently occurring distant to the notch. The test can also be performed with an unnotched specimen or the notch reversed. Test results are always reported with respect to notch presence and position, (see ■ FIGURE 28).

(c) Tensile test

This test uses a similar swinging pendulum to the previously mentioned test methods. The test specimen is mounted so as to facilitate measurement of the energy required to fracture the bar under tensile impact loading, (see ■ FIGURE 29).

5.2.2 Falling weight methods

In this test a weight (dart) is allowed to fall onto a specimen, under defined conditions, as illustrated in ■ FIGURE 30. The procedure is then repeated with successive increases as a product of dart mass and drop height. Preferred methods are those which keep a constant height and vary the dart mass, since speed at the point of impact remains equal.

A modern, instrumented form of the dart puncture impact test is the Dynatup impact test. In this test, head velocity and force are measured continuously and are output along with a computer calculated energy absorption curve. For ductile polymers, the energy to failure measured in a falling dart test is a complicated function of the yield stress, draw-strain, post-yield modulus and ultimate failure stress of the material, none of which can be fundamentally measured by the test.

■ FIGURE 30
Illustration of falling dart impact test configuration

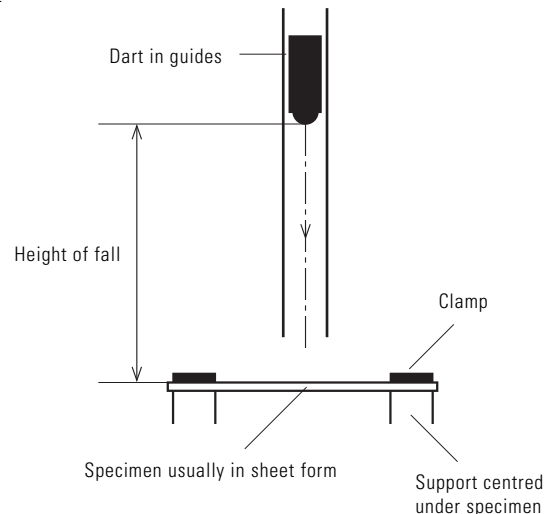

5.3 Design considerations

It is well-established that strain rate and temperature have a distinct effect upon the yield stress, (σ_{yield}), of a polymer. The relationship between stress and strain rate takes the form:

$$\sigma_{\text{yield}} = B_1 + B_2 * \ln(\text{strain rate})$$

where B_1 and B_2 depend upon the polymer and the temperature.

In general, higher rates and lower temperatures lead to high yield stresses, and lower rates and higher temperatures lead to lower yield stresses.

The interrelationship of strain rate and temperature with regard to ductile-brittle transitions can be seen in

■ **FIGURE 31.** Two sets of curves are shown, one describing the brittle stress at two strain rates for a hypothetical polymer as a function of temperature; the other describing the yield stress of the same material for the same strain rates.

Although the brittle failure stress usually shows only a small dependence on rate, the yield stress is affected much more significantly. Furthermore, the yield stress usually also shows a stronger dependence on temperature than the brittle failure stress as reflected in the steeper yield curves as a function of temperature. The net effect is that, as the strain rate is increased, the transition temperature defining the boundary between ductile and brittle failure moves to a higher level.

Due to the many factors which can influence the ability of a plastic component to absorb impact energy, combined with the problem of relating standard test results to application requirements, it is recommended that all final designs be fully tested for applications where impact is a serious performance issue.

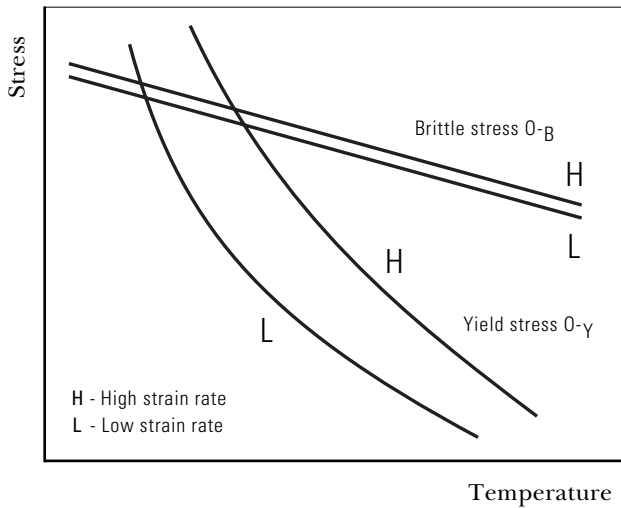

■ **FIGURE 31**
Graph illustrating ductile-to-brittle transition in failure

6

Design for appearance

6.1 Introduction

This Chapter looks at applying guidelines to achieve the best possible surface appearance for parts produced by the injection moulding process with engineering thermoplastic materials.

6.1.1 General remarks

The nature of the polymer chosen is an important factor in obtaining a good surface finish. Glass-filled materials in general have a relatively poor surface finish compared to unfilled polymers. The discussion about surface quality of injection moulded parts is not really an objective one, because the perception of quality is different from person to person. The topics discussed in this chapter therefore should be considered as guidelines to create surfaces with minimized defects rather than absolute quality criteria.

6.2 Surface defects

The surface defects discussed below are only a selection of the wide variety which is possible, and are more or less related to design. It should be noted that mould steel quality and surface finish of the cavity play a major role in hiding surface defects.

6.2.1 Sink marks

Sink marks typically occur where projections such as ribs or bosses meet the main surface of a plastic component. The cause of this type of sink mark is the local increase of thickness at the location of the projection in the visible main wall, which suffers a higher than average shrinkage. (Refer to Chapter 8 'Design for Mouldability', ■ FIGURE 50 and 51). To minimize this effect, the mating wall thickness should be kept down to 50% of the main wall.

The amount of shrinkage is also influenced by gate design, material type and process conditions. The risk remains

that a slight sink mark will occur, especially far away from the gating point. A textured finish to the cavity wall might hide the defects but it is seldom possible to create a high quality surface when applying ribs, bosses or sudden wall thickness transitions.

A compromise can be found by using styling features like grooves or a step in the surface where a rib is mating the critical surface, (■ FIGURE 32). Gas-assisted injection moulding is a technique which can greatly reduce sink marks, but gloss differences are difficult to avoid, (■ FIGURE 33). It has to be realized that locations far away from the gating points, combined with thin walls and a relatively small gating system, increase the risk of unacceptable sinkmarks.

6.2.2 Weld lines

A further phenomenon causing possible surface defects is the formation of weld lines which occur where flow fronts meet. It is recommended to locate the injection points in the least sensitive areas, (■ FIGURE 34), considering critical locations such as around holes or between gating points.

Flow simulation is a very useful way of predicting the location of weld lines before the gating system is cut into the mould. Adequate venting in the weld line areas at the outer edge can reduce the visibility of weld lines, but, in most cases, will not eliminate them.

6.2.3 Air traps

Air traps are undesired areas in a moulding which occur when there is insufficient venting at the edge of a moulding, or when air is trapped as the outer area of a component fills before the area closest to the gate. This can result in burned spots due to diesel effects.

■ FIGURE 32

Styling features can be applied to hide sinkmarks caused by ribs or bosses

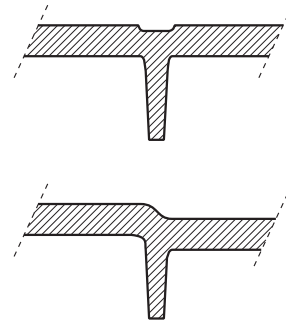

■ FIGURE 33

Gas-assist Injection Moulding Technology can be used to reduce the sinkmark behind the boss. Gloss differences however may occur!

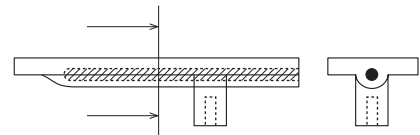

■ FIGURE 34

The position of the gate determines the location of the weldline. Around apertures a corner is quite often the best location to position a weldline from cosmetic point of view.

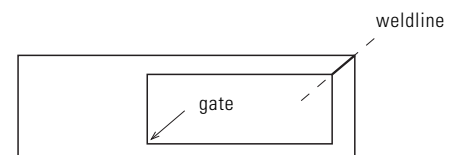

■ FIGURE 35

Sharp transitions might cause the plastic to lose contact with the mould for a short period of time. This can result in airtrapping.

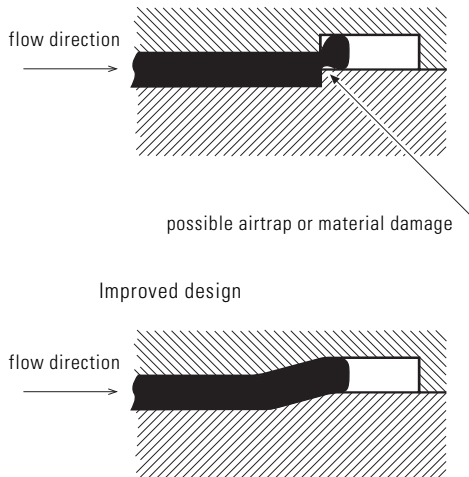

Quite often this can be avoided by a slight wall thickness increase between the gating point and the air trap flow leader.

Rib shapes blindly spark-eroded into a mould can also cause air traps. This might cause problems when filling the rib, and the material might overheat by diesel effects. Venting has to be provided in this case by ejector pins, porous inserts or other venting constructions.

Air traps can also occur on the surface of a part when sudden changes in wall thickness occur. The melt stream locally loses contact with the cavity surface and, as pressure builds up, is then forced against the surface with a volume of air between the plastic and the mould. This air is compressed at very high speeds, which can raise the temperature and degrade the surface locally, (refer to ■ FIGURE 35). In practice this can cause for example bad paint adhesion or poor impact behaviour.

6.2.4 Voids

Voids can be described as air bubbles which are only visible in transparent materials such as Lexan® resin. They can occur in very thick areas of a component and are caused by excessive shrinkage. Normally this phenomenon can be avoided by not using thick sections relative to the rest of the part. If these cannot be avoided, special care should be taken to design a large enough gating system and apply sufficient packing pressure and time.

Voids can also occur due to insufficient predrying or too much decompression in the barrel in front of the screw.

6.2.5 Streaks

Streaks on the surface of a plastic component can be caused by moisture, degradation in the machine barrel or hot runner system or by overshearing. Looking at the relationship with design, overshearing can occur due to a gate being too small. Computer simulation can help to determine the level of shearing and adapt the gate or runner dimensions to achieve an acceptable level of shear. Typical safe shear levels in gates are 20.000 - 25.000 sec⁻¹ for GE Plastics' engineering thermoplastics.

6.2.6 Delamination

Delamination occurs when there is insufficient adhesion between the frozen skin and the molten inner material of a plastic component and, consequently, layers can be peeled off easily. The main causes are processing with material which is too hot and/or with injection rates which are too high. If the problem cannot be solved by slower injection rates and suitable melt conditions, the gating system can be modified with larger gate and runner dimensions. This will reduce shear rate which can be one of the causes of local material degradation.

6.2.7 Jetting

Small gate openings directing the polymer flow into an open space can cause jetting. The polymer expands after passing the gate, cools rapidly and builds a strand of relatively cold material in the cavity, (see ■ FIGURE 36). After a certain time, pressure builds up in the cavity and the remaining injection volume fills the cavity normally. The initial cold strand is visibly embedded in the rest of the polymer and causes a reduction in the mechanical strength of the material. To avoid jetting, gates should be positioned so that the polymer stays in contact with the cavity wall after passing the gate opening, (■ FIGURE 37).

Injection speed and melt temperature can also influence jetting to a certain extent; the lower the injection speed and melt temperature, the lesser the risk of jetting.

6.2.8 Gate marks

When small gate openings are used in combination with high injection speeds, there is a risk of gate marks. These will show up in general as matt spots around the gate area. The explanation of this phenomenon is that the material is extremely highly oriented in and directly after the gate. The outer layer is frozen in this highly oriented situation. After filling, the inner layer can relax much more than the oriented thin outer layer. This creates high stress levels during cooling, causing micro cracks. These will again show up as matt spots, because the light refraction is different compared to the environment of the gate area. This problem can also be reduced by larger gate and runner dimensions and slower injection speeds.

6.2.9 Summary

Surface defects can be divided into the following categories:

(a) Material degradation

Material degradation can occur in the machine barrel or the hot runner system, (refer to Chapter 7 for process-related factors). Hot runner systems are quite often the cause of material degradation. Wrong dimensions, inadequate temperature control, and hang up areas are the most important factors. Flow simulation can help to determine the correct hot runner channel diameters. They should be big enough to prevent overshearing and small enough to achieve reasonable residence times.

(b) Moisture in the material

This problem can be prevented by proper predrying of the material before moulding. Water leakage in the mould can also be a cause of moisture streaks.

(c) Component design

Wrong wall thickness ratios of bosses, ribs and other projections are common causes of sink marks. Basic design principles can help to avoid certain surface defects. A typical ratio for features perpendicular to the visible surface is 50% of the main wall thickness. The location of the feature relative to the gate position is important: the further away from the gate, the bigger the risk of sink marks.

Wall thickness transitions are another cause of visible marks on the surface of the part. These should be smooth and not sudden.

Sharp corners in a mould can cause air traps or damage the passing material. This should be avoided whenever possible.

(d) Runner and gate design

Small cold runners and gates create high shear rates and temperatures in the melt during the filling stage which, as discussed, can cause several types of surface defect. Flow simulation can assist in determining runner and gate sizes to achieve acceptable shear and pressure levels.

■ FIGURE 36

Small gates positioned opposite open cavity area can produce jetting. The strand cools down and later on is embedded in the part, causing bad cosmetics and lower mechanical properties.

Side view

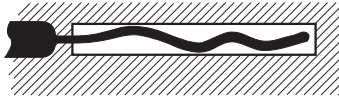

Top view

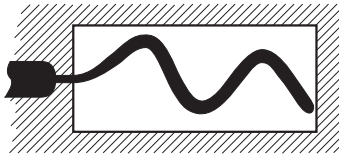

■ FIGURE 37

To avoid jetting put the gate in such a way that pressure is build up immediately in the beginning of the filling stage.

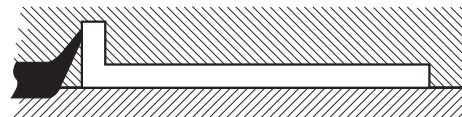

If the design can not be changed according the example illustrated above, an ejectorpin can be used for gating.

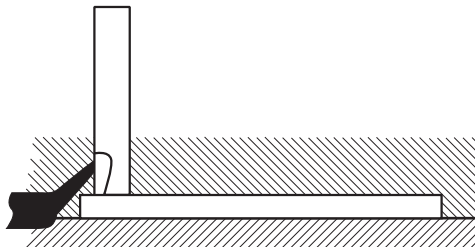

Design for precision

7.1 Introduction

Designing for precision can be defined as applying guidelines when designing a component and the corresponding mould, to mass produce thermoplastic components using the injection moulding process, within as narrow as possible dimensional tolerances. The discussion of precision is strongly related to the way a plastic component shrinks after the injection moulding process. This chapter deals with various shrinkage mechanisms which occur both during moulding and as secondary effects.

7.1.1 Mould shrinkage

Shrinkage or mould shrinkage can be defined as the difference between the moulded component dimensions and the corresponding mould cavity dimensions. Normally this phenomenon is expressed as an average percentage. This is used by the mould maker to add to the desired component dimensions as a target for the mould dimensions.

As can be seen in ■ FIGURE 38, the shrinkage of a component is a time/temperature related process. Most of the shrinkage occurs directly after part

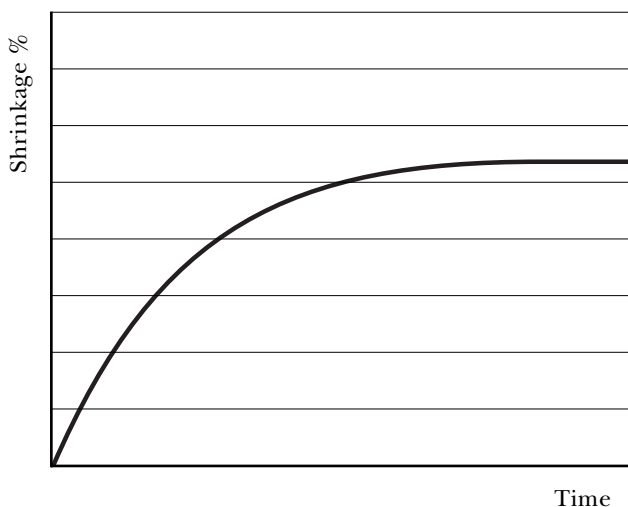

■ FIGURE 38
Most of the shrinkage occurs directly after part ejection. As part cools down to room temperature final mould shrinkage will be reached

ejection. As the part cools down to room temperature, final mould shrinkage will be reached. Quite often this phenomenon creates warped parts, because the shrinkage of the component during cooling to room temperature is not even, depending on the design and the injection moulding process.

7.1.2 Secondary effects

Sometimes components are heated after moulding for example during paint curing. This operation can also cause both permanent and temporary dimensional changes.

External loads and moisture absorption have an added influence on dimensions.

7.2 Shrinkage phenomena

There are three key factors governing shrinkage behaviour: cooling, packing and orientation.

7.2.1 Cooling

Uneven cooling can cause differential shrinkage. Uneven cooling is caused by mould surface temperature differences during the cooling process.

This problem can be minimized by optimizing the cooling circuit. This means minimizing the temperature difference of the cooling medium between the beginning and the end of cooling circuits, and selecting the right distance to the cavity wall and the right distance between channels.

Areas which are difficult to cool can be avoided by part design or through the use of highly conductive metals in the relevant sections. Corners are difficult to cool evenly, as there is always the tendency for the outside to cool faster than the inside. As can be seen in ■ FIGURE 39, this phenomenon can cause walls of boxes to warp inwards.

■ FIGURE 39

Corners are difficult to cool at the same rate internally and externally. Tendency to distort.

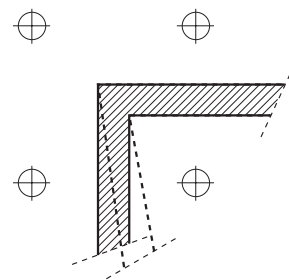

Applying a generous radius the cooling can be more even, hence less problems with distortion

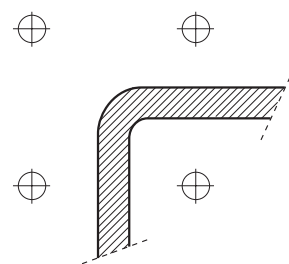

This effect can be reduced by giving the corners an internal radius and by keeping wall thickness constant. Location of cooling lines inside the part can be optimized by positioning the channel closer to the corner. Computer simulation programmes can assist in this process.

Depending on the nature of the plastic used, the level of mould temperature determines the degree of crystallinity, which has an influence on the level of volumetric shrinkage.

7.2.2 Packing

The packing or holding pressure phase has a significant effect on shrinkage. In general, the higher the holding pressure and the longer it is effective, the smaller the shrinkage.

This can be explained by the PVT relationship of thermoplastics, (see ■ FIGURE 40).

In order to really influence the packing stage, it is important to create sufficiently large gate openings and cold runners as the moment of gate or runner freeze-off determines the end of effective packing.

7.2.3 Orientation

The third important factor related to shrinkage behaviour is the orientation of molecules and fibres. Orientation effects cause different shrinkage in flow and cross-flow direction, which can influence the flatness of parts significantly.

Apart from material choice, the method of gating plays a major role.

7.3 Materials and shrinkage

7.3.1 Amorphous materials

Amorphous materials exhibit lower shrinkage than semi-crystalline materials. Furthermore, the levels of shrinkage in flow and cross-flow direction are closer for amorphous materials.

It is therefore easier to produce precise parts with amorphous, unfilled materials than with fibre-filled or semi-crystalline materials.

Typical examples of GE Plastics' materials with a mainly amorphous character are Lexan® polycarbonate, Ultem® polyetherimide resin, Cycolac® ABS resin, Cycoloy® polymer blend and Noryl® PPO® resin.

■ FIGURE 40
Typical PVT relationship for amorphous plastics. Higher holding pressure reduces volumetric shrinkage

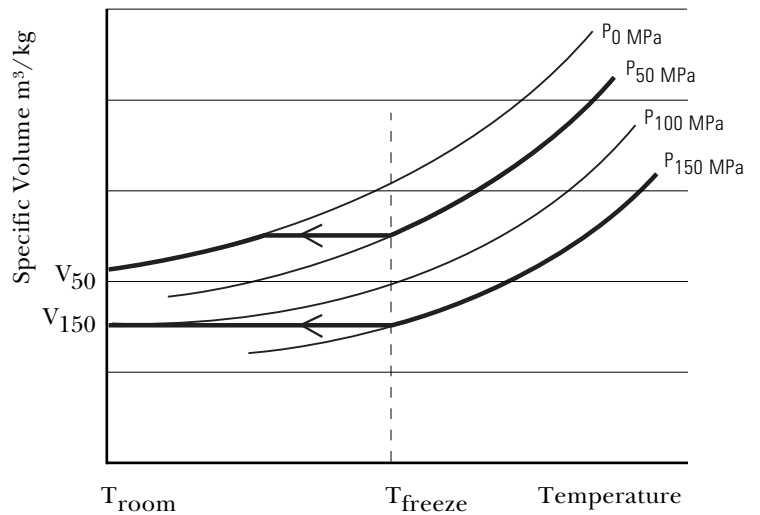

Typical PVT relationship for semi-crystalline plastics. Crystalline materials shrink more than amorphous ones due to crystallinity.

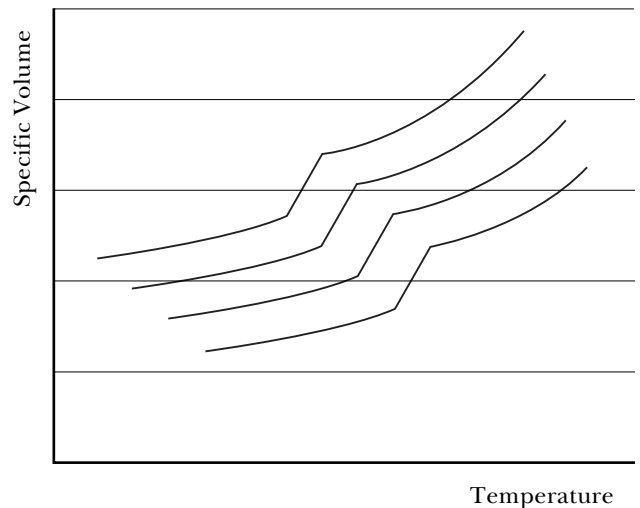

7.3.2 Semi-crystalline materials

Semi-crystalline materials exhibit higher shrinkage than amorphous ones. Therefore parts made out of this type of material, or similarly fibre-filled materials, often suffer distortion due to differential shrinkage. Typical examples of GE Plastics' materials with a semi-crystalline behaviour are Valox® thermoplastic polyester resin, Lomod® flexible engineering thermoplastic resin, Noryl® GTX modified PPO® alloy, and some grades of Xenoy® thermoplastic alloy.

7.3.3 Reinforced materials.

Both amorphous and semi-crystalline materials have a more orthotropic character when glass-fibre filled; in other words, the difference between flow and cross-flow shrinkage increases. The most difficult polymers for precision moulding are glass-filled semi-crystalline resins because they already have a higher shrinkage level, they are sensitive to crystallinity levels and the fibres increase the sensitivity to orientation. To reduce warpage tendency thermoplastics are sometimes filled with minerals, which provides good temperature resistance combined with a lower warpage tendency, but lower mechanical strength.

7.4 Design related factors

7.4.1 Part wall thickness

Wall thickness is an important factor when designing for precision. Thin parts are more sensitive to orientation because they have to be filled quickly, and the cooling time available is very short. This provides minimal time for thin parts to be corrected in the holding pressure phase.

Parts with different thicknesses suffer from distortion, because the different thicknesses exhibit different degrees of shrinkage. However, the phenomenon of differential shrinkage can also be used as a benefit. A centre-gated disk type of part, for instance, with warpage tendency, can be forced into a repeatable shape by making the centre section thicker. This is in order to control the holding pressure for a longer time and so force a lower level of shrinkage in the centre of the component, (refer to ■ FIGURE 41).

7.4.2 Ribs

Uneven shrinkage applies in particular to parts with ribs, where the ribs are sometimes 50% of the nominal wall thickness to prevent sink marks. The ribs cool much faster than the main wall, which will shrink more due to a longer available cooling time. In practice this means that it is almost impossible to make flat parts with thin, long ribs, (see ■ FIGURE 42).

Gas-assisted injection moulding is an option which is increasingly used to control the differential shrinkage between the rib and main wall, by creating a hollow channel in the crossing point of rib and wall. In such instances, the rib can have the same thickness as the main wall, (see ■ FIGURE 43).

7.5 Mould related factors

7.5.1 Gate location

The choice of gate location is extremely important when designing for precision parts. Often the choice is a compromise between precision and productivity. For example, an ideal gate choice for a plate type of component is a film gate along one of the sides of the component, (see ■ FIGURE 44). However, this option is frequently not chosen due to the disadvantages of removing such a gate.

In summary, the chosen gate location should provide a short flow length, uniform orientation, and optimum pressure distribution at fill.

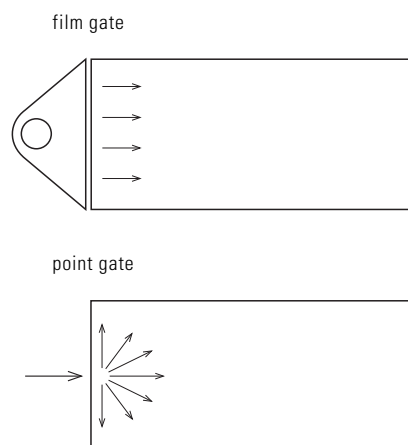

■ FIGURE 41

Centre gated disk with thicker centre section allows for more controlled holding pressure to get a flatter part

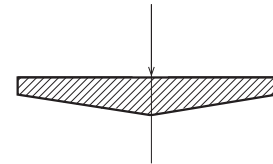

■ FIGURE 42

Thin rib shrinks less than thick mainwall, resulting in permanent deformation



■ FIGURE 43

Using gas-assisted injection moulding technology, ribs can be used with minimised warpage and sinkmarks. Gloss differences can occur.

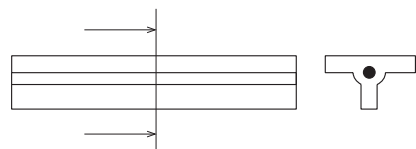

■ FIGURE 44

Film gate produces more uniform orientation compared to point gate and therefore less warpage tendency

7.5.2 Gate type

The gate type is often predetermined for cosmetic or economic reasons. As with gate location, a compromise is often necessary in its selection, because of the difficulty in combining optimum precision, cosmetics and cost efficiency.

There are basically two gate types: the round gate like tunnels, direct sprues and pinpoints, and the rectangular-shaped gate such as tab gates and film gates. It can be said that, in general, point gates create high orientation levels in the gate area, which will frequently lead to distortion, whereas wider film or tab gates tend to bring a more uniform orientation into a component.

If a point gate is really essential, sometimes an increase in the number of gating points can bring a more uniform orientation pattern to a component, as well as giving better control in the holding pressure stage due to shorter flow lengths.

7.5.3 Gate size

Small gates create more shear, orientation and pressure loss than larger ones. They also limit the effect in the packing stage. In general, the gate diameter or thickness should be at least 60% the thickness of the main wall, although preferably larger, in order to provide the largest possible processing window. Film gates have the advantage of producing a low shear rate and uniform orientation, but are more difficult to remove after moulding.

7.6 Processing related factors

7.6.1 Melt temperature

Melt temperature has an effect on shrinkage as an absolute value. Looking at shrinkage differences is less significant. Of course a higher melt may lead to a reduced average shrinkage percentage, and hence to less differences, but it is not a major factor in shrinkage control within a component.

7.6.2 Mould temperature

Mould temperature has an influence on shrinkage. A higher mould temperature allows for more crystallization of semi-crystalline materials. Furthermore, the relaxation time is longer, which means some orientation effects are reduced.

However the cooling times will be longer and extremely high mould temperatures require special equipment like oil heaters or high pressure hot water devices.

7.6.3 Injection time

The time to fill a cavity influences the orientation level in a moulded component: the higher the injection speed, the more orientation occurs. At the same time, the filling speed has an influence on the temperature distribution at the moment the cavity is filled and the packing pressure starts to be effective. Depending on geometry and chosen gating, both the orientation and the temperature of the material have an effect on the final shape of the part. The injection phase therefore plays an important part in controlling the shrinkage and warpage of an injection moulded component.

7.6.4 Packing pressure

Packing pressure is one of the most important variables to consider when trying to control shrinkage. The way a component is packed determines the final specific volumetric shrinkage in each area of the component. The more uniform the volumetric shrinkage over the whole part, the more likely the part will come close to the desired shape with a minimum of distortion.

7.7 Secondary effects

After ejection and cool down, a component can still suffer unwanted deformation.

In particular when temperature changes occur during usage, there are a number of phenomena which can temporarily or permanently cause dimensional changes due to thermal expansion and post crystallization.

7.7.1 Thermal expansion

When a component has to perform at elevated temperatures, thermal expansion will cause the part to become larger. Glass- or mineral-filled materials will suffer less from this phenomenon. If critical stress levels are reached, permanent deformation can occur, (refer to section 7.7.4 - Creep under load).

7.7.2 Moisture absorption

Another effect on dimensions will occur through water absorption. PA-based materials such as Noryl® GTX resin are prone to this phenomenon.

7.7.3 Post crystallization

Semi-crystalline materials, such as Valox®, Noryl® GTX and Lomod® resins, can exhibit post shrinkage, especially when used at elevated temperatures due to post crystallization.

7.8 Simulation techniques

Today several computer programs are available to calculate the expected shrinkage phenomena due to the injection moulding operation. These programs can assist the design engineer in evaluating different alternatives of gating and processing combinations, as well as comparing the shrinkage behaviour of different materials.

Thermal expansion and, to a lesser extent creep, can be computer-simulated with commercially available non-linear finite element analysis programs, (see Chapter 2).

7.9 Summary

Major factors influencing shrinkage include:

(a) Material:

Amorphous materials exhibit less shrinkage than semi-crystalline materials; glass fibres increase sensitivity for orientation but have a lower shrinkage.

(b) Gate location

The choice of gate location dictates the orientation of material, which can have a dramatic effect on shrinkage and warpage behaviour.

(c) Gate shape

The size and type of gate can influence the level of orientation and hence the shrinkage behaviour. In addition, the gate and cold runner size determines the effectiveness of the packing phase, which has an impact on shrinkage and warpage.

(d) Part thickness

Wall thickness influences the orientation level of plastic parts: the thinner the wall, the more orientation due to shorter injection times. Minimum influence on the packing stage limits the control over shrinkage.

(e) Ribs

Ribs are normally thinner than the main wall thickness to reduce sink marks. This causes a different shrinkage in rib and main wall, resulting in distorted parts. In particular this is a problem with long ribs.

(f) Injection speed

Injection speed is related to the orientation of the material: the higher the injection speed, the more orientation. Especially in combination with small pinpoint

gates, this effect is considerable.

The end result will be increased differential shrinkage between flow and cross-flow direction.

(g) Holding pressure

The effect of holding pressure level and time is one of the most critical factors with respect to shrinkage. High and long holding pressures create less shrinkage than short and low holding pressures. The size of the gating system has to be taken into account; a small gating system, (gates and cold runners), can reduce the effects of holding pressure dramatically.

(h) Mould cooling

Mould temperature differences have a further effect on shrinkage. Temperature variations in the cavity wall can cause different cooling rates and hence different degrees of shrinkage. Therefore mould cavity temperature should be kept as constant as possible.

(i) Process consistency

In addition to the basic principles regarding shrinkage and warpage, the quality and consistency achieved during processing are critical. In particular, temperature of melt and mould, injection profiles and pressure control play a major role in assuring shot-to-shot consistency for accurate dimensions.

(j) Secondary effects

The impact of additional loads on dimensional changes of injection moulded parts during usage should not be overlooked. Heat loads, mechanical loads and water absorption are typical examples of detrimental external influences.

Design for mouldability

8.1 Introduction

Optimum design for mouldability provides the possibility to obtain thermoplastic parts in their final finished shape without any secondary operations and with no waste of material.

The injection moulding process is widely used for the production of plastic components. In the injection moulding machine the material is melted and homogeneously plasticized by means of a screw inside a heated cylinder. The molten and homogeneous plastic mass is injected under high pressure via the machine nozzle into the cavity of the mould. In the mould cavity the material is cooled down and the part is ejected from the mould when sufficiently rigid.

The injection moulding process offers many advantages. In particular it offers the possibilities for:

- Highly complex parts
- Repeatability of tight tolerances
- Moulded-in features like bosses, snap-fits, ribs, undercuts and holes
- High quality surface properties
- Ease of automation for large production runs.

8.2 Material issues

To obtain large parts from an injection moulding machine, the material's flow properties are critical. These are measured based on melt flow length and melt temperature.

8.2.1 Melt flow length

The melt flow length of a material is a measure of how easily a material can flow to fill a part. It indicates the length that a material can flow under a specific set of common moulding conditions. Determination of melt flow length is important when trying to predict if a part can be filled or not. It is commonly

shown in a graph as flow length versus wall thickness at a variety of initial melt temperatures, (see ■ FIGURE 45).

Melt flow data are generated using a spiral flow tool under processing conditions which are considered common for the material. The initial melt temperature, mould temperature and injection pressure must be recorded together with the data curve because they significantly influence the distance of flow.

The melt flow length of a material is a function of viscosity, thermal properties and shear properties.

8.2.1.1 Viscosity

Viscosity determines the resistance of the material flow due to internal resistance at a given melt temperature. For example, water has a low viscosity, molasses a high viscosity and molten plastic an even higher viscosity. The internal resistance of the material

flow is caused by the internal shear stresses within the melt. From a chemical or molecular point of view, the viscosity of a material is a function of the molecular chain length of adjacent polymers and the strength of the bonding between them. In other words, it is a function of the energy required to cause relative motion between the adjacent molecules.

Factors affecting viscosity:

The viscosity of a material will largely be a function of its temperature and of the amount and type of any fillers or additives present. Viscosity generally functions inversely with respect to temperature: an increase in temperature usually causes a decrease in material viscosity. Fillers and mineral additives tend to increase viscosity, while plasticizers, impact modifiers and wear enhancers tend to decrease viscosity. Molecular weight also significantly influences viscosity: higher molecular weight polymers generally have higher viscosities.

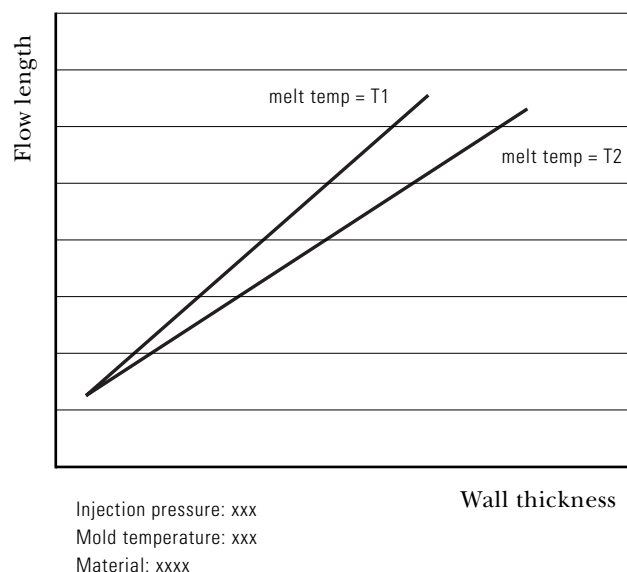

■ FIGURE 45
Melt flow length

Common viscosity tests:

Some of the common viscosity tests are as follows:

MELT VISCOSITY (MV):

This measures the time it takes for a specific amount of molten material at a fixed temperature to be extruded through an orifice at a constant pressure.

MELT FLOW INDEX (MFI):

This measures the amount of molten material which can be extruded through an orifice under a fixed pressure over a specific amount of time.

8.2.1.2 Thermal properties

The thermal conductivity and specific heat of the material will determine how quickly the flow front will cool down, which in turn greatly affects material viscosity.

8.2.1.3 Shear properties

When shearing occurs in the melt, the temperature of the material will rise causing the material to flow more easily. Some materials, such as nylon, heat up and flow much more easily when exposed to large amounts of shear and yet retain much of their original mechanical properties. These materials are said to be shear insensitive.

Conversely, most of GE Plastics' materials are shear sensitive as they can be significantly damaged by being exposed to large amounts of shear. Shear curves showing the relationship between shear rate and viscosity at different temperatures are required for accurate injection moulding simulation, (see ■ FIGURE 46).

8.2.2 Melt temperature

The melt temperature of the injection moulded material is also an important parameter. Thermoplastic materials become less viscous as temperature increases. Crystalline materials have a clearly defined melt temperature, (T_m), above which they lose all structural integrity and flow freely. Amorphous materials soften over a wide temperature range above their glass transition temperatures, and therefore do not actually have a specific melting point or temperature. Above the glass transition temperature the material is more ductile and behaves in a rubbery manner.

8.3 Shrinkage

8.3.1 General remarks

All thermoplastic materials contract during a temperature transition from a molten state to room temperature as they cool down and solidify after being plasticized. As a result of this, when designing a mould, it is necessary to make the core and cavity slightly larger in dimension than the finished component size. The difference in dimensions which exists between the mould and component is known as the mould shrinkage. Mould shrinkage can vary considerably, depending on the mould geometry and processing conditions. For example, thin walled components exhibit less shrinkage than those with thicker walls.

When screening materials for particular applications it is important to understand the different shrinkage characteristics of amorphous and crystalline types of resin. The degree of crystallinity of the resin has a major influence on shrinkage: crystalline resins tend to shrink more than amorphous ones which can be explained by examining the morphology of both materials. Amorphous polymers are isotropic and display approximately equal shrinkage in both flow and cross-flow direction. Crystalline polymers are anisotropic and therefore display different shrinkage in flow and cross-flow direction. (For more detail see Chapter 7).

■ FIGURE 46
Factors affecting viscosity

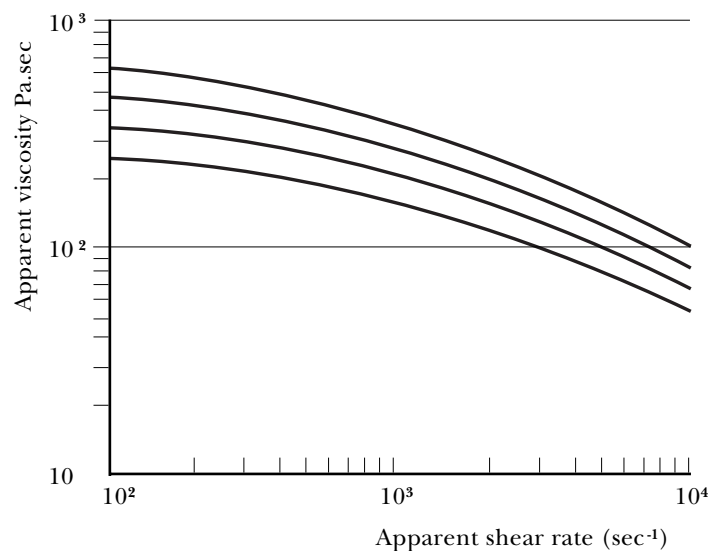

Viscosity vs shear rate
curves represent different processing temperatures

8.3.2 Warpage

Warpage typically occurs in anisotropic materials and is caused by different shrinkage in flow and cross-flow direction.

Differential shrinkage can be caused by any of the following:

(a) orientation glass fibres

With unfilled crystalline resins the greatest shrinkage is usually encountered in the flow direction. With glass-reinforced polymers the shrinkage in the flow direction can become less than in cross-flow direction due to the orientation of the fibres. Illustrations of mould shrinkage can be seen in

■ FIGURE 47 and 48.

(b) geometric asymmetry

Warpage can also be caused by the part geometry. If a number of parallel ribs are used on just one side of a part which is intended to be flat, shrinkage in the ribs can cause the top surface to warp.

(c) asymmetric cooling

If cooling is not well-distributed in the part, differential shrinkage can lead to warpage.

(d) highly aligned flow

In semi-crystalline polymers, regions of order tend to align themselves with flow in parts where there is a highly oriented flow pattern.

(e) voids

If a thick section exists in the part, the material on the outside skin will cool down first and consolidate. As the centre area over the part wall thickness finally cools down and tries to shrink, the outer skin cannot accommodate it because it has already frozen off. As it shrinks, the material in the centre area pulls towards the outer skin, forming a vacuum bubble or void in the centre.

(f) sink marks

If a thick section exists in the part in areas such as intersections of thick ribs with the nominal part wall thickness, the centre area in this thick section can cause the surface of the outer wall to be distorted or pulled in.

(g) ejection problems

If a circular, square or cylindrical shape is moulded, it will shrink onto

the core of the mould if adequate draft is not included. The shrinkage can pull the sides of the part onto the core and lock a vacuum which prevents ejection.

8.4 Cooling time

The cooling rate is important to consider when designing a plastic part because it is the primary determining factor of cycle time and therefore processing costs. In general, cooling time is strongly affected by the thermal conductivity and specific heat of the material and the part geometry.

(a) specific heat

The specific heat of the material dictates the thermal energy per degree of temperature change which is desired.

(b) thickness

The thickest area of the part will be the last to fully cool down. It will therefore dictate the amount of time which the part must remain in the tool while cooling.

(c) tooling

The tooling for the part should be designed with cooling lines in critical areas to remove heat. Up to a point, the greater the capacity of the cooling system, the faster the part can be cooled and removed from the tool. Once a certain point is reached, the conductivity between the steel and the plastic in the tool will dictate the rate of cooling regardless of a further increase in the cooling system's capacity. It should be noted that excessively cooled cavities can cause the part surface to shrink away from the cavity wall. This prevents thermal conduction and required thermal convection from being the primary modes of heat transfer, thereby imposing much longer cooling times.

The cooling rate can be increased by thinning part walls and providing improved cooling in the tool. Cooling time for a part is often predicted using material cooling data. This is presented in the form of a graph showing cooling time as a function of maximum part thickness for a specific material. This is calculated at the recommended melt temperature, under standard moulding conditions and with adequate mould cooling.

■ FIGURE 47
Mould shrinkage

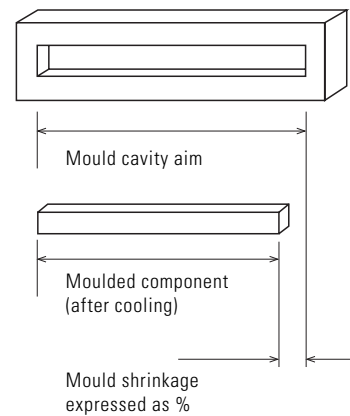

■ FIGURE 48
Shrinkage of anisotropic resins

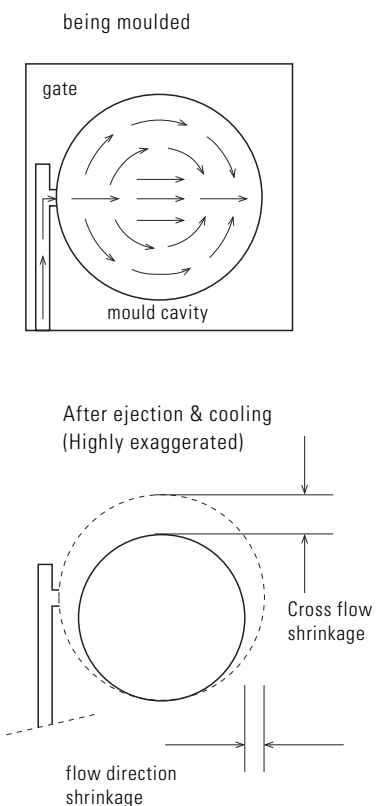

■ FIGURE 49

Wall section transition

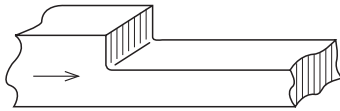

Sharp - not recommended

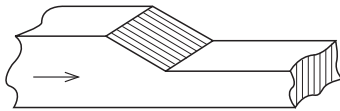

Tapered - better

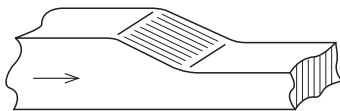

Gradual - recommended



Direction of flow during injection moulding of compact resins

■ FIGURE 50

Projection

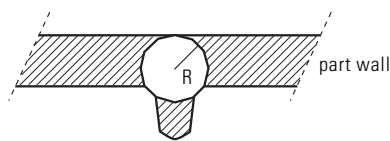

8.5 Design considerations

8.5.1 General remarks

When designing thermoplastic components, general guidelines should be considered. Exact recommendations are sometimes impractical, since variables such as component geometry, production process and individual requirements may dictate certain design features.

8.5.2 Nominal wall thickness

The nominal wall thickness forms the basic frame or shell of a component. All other details are added to this shell structure and will affect, or be related to, the part wall thickness. It is important that the nominal part wall thickness should be correctly designed. A wall section which is too thin can lead to structural failure or poor insulation characteristics, whilst a wall section which is too thick, even locally, can result in appearance defects and an overweight or over-engineered component.

The actual wall thickness is generally related to the overall size of the part and gate locations. Also the flow characteristics of the particular material being specified should be taken into account. Ideally the nominal wall thickness is kept constant due to shrinkage and cooling related issues, but in reality this is usually impractical.

In most applications, a thin, uniform wall with ribs is preferred to a thick wall, for optimum part requirements, strength to weight ratio and cost effectiveness.

Where changes in thickness are involved, care should be taken that the direction of the melt flow during the moulding process is always from a thick area into a thinner section. This flow direction promotes higher cavity pressures, which minimize sink marks and reduce the risk that a part cannot be completely filled. ■ FIGURE 49 shows a series of wall section transitions, with the arrows indicating the melt flow direction during injection moulding.

Wall thickness variation influences cooling rates of the moulded component and unequal thickness causes an imbalance of cooling and possible flow problems during moulding, which can result in warping and appearance defects. Additionally, sharp corners act as stress concentrators which can often lead to premature failure.

8.5.3 Projections

Due to shrinkage and cooling time related issues associated with thick sections, the projection determines the size of the isolated mass or thickness. The projection can be determined by obtaining a large scale cross-sectional drawing of the intersection and inscribing the largest possible circle in that area, as shown in ■ FIGURE 50.

When considering alternative designs for this area, the smaller this circle is, the better for cooling. A recommended approach is to estimate the radius as the largest distance in all directions from a small area of material to reach mould steel. This gives the distance which the thermal energy must conduct away from that area of material in order to get to the steel where it can be removed.

8.5.4 Radii

Chapters 2 and 3, stiffness and strength, discussed a large number of mechanical and performance related reasons for incorporating large radii. They are also important to the reduction of stress concentration which can be defined as the magnification of the level of an applied stress in the region of a notch, void or hole. In most cases, the stresses in these regions will be far greater than calculated stresses which are based on assumptions as to stress distribution.

Because of the general notch sensitivity of plastic resins, care should be taken to include generous fillets and radii in areas which include sharp changes in section or direction. In addition to these structural reasons, the avoidance of sharp corners:

- * facilitates part ejection: Sharp internal corners tend to stick in the mould as the part shrinks onto the core.

- * provides smooth flow: Resin flows much more easily and less turbulently around smooth uniformly radiused corners than sharp corners. This reduces the pressure drop around the corner, thereby reducing the total required injection pressure.

- * reduces shear: Shear induced by flow around sharp corners can degrade the polymer's mechanical properties and cause blush and other aesthetic problems.

8.5.5 Ribs

To increase the load carrying ability or stiffness of a plastic structure, it is necessary to increase either the properties of the plastic material or the sectional properties of the structure. One method of increasing the component stiffness, without increasing the overall wall thickness or involving a large weight increase, is the incorporation of ribs.

Ribs offer structural advantages but they can also result in warping and appearance problems. To achieve a successful rib design the following guidelines are suggested, (refer also to ■ FIGURE 51):

- In order to reduce sink marks on prime appearance surfaces, the base thickness of the rib should not exceed 50% of the adjoining wall thickness. This however, may be increased when appearance is less critical.
- To reduce possible overstressing, filling and ejection problems, the height of the ribs should not exceed three times the adjoining wall thickness. When increased strength is required, more ribs of the specified proportions are recommended in preference to an increase in rib height.
- A minimum radius of 25% of the adjoining wall thickness should be incorporated at the base of the ribs, since sharp corners act as stress concentrators. Radii larger than 50% of the adjoining wall thickness only give marginal improvements and may result in sink marks on the opposing surface.
- Ribs are most effective when placed down the length of the area subjected to bending.
- Rib spacing should be at least twice the nominal wall thickness.
- A draft angle of at least 0.5 degrees on each side should be incorporated in order to facilitate release from the tool.
- Care should be taken to ensure adequate tool venting where gas traps are likely.

8.5.6 Support ribs

Support ribs may be considered as a form of reinforcement for corners, side walls or bosses. For the successful introduction of support ribs the following guidelines are suggested, (refer also to ■ FIGURE 52):

- The thickness of the support rib should be between 50% and 70% of the component wall thickness.
- The minimum distance between faces of successive support ribs should be twice the component wall thickness.
- The minimum length of the support rib face attached to the component wall should be twice the wall thickness.
- Generous radii should be incorporated at the ends of the rib.
- A minimum draft angle of 0.5 degrees should be incorporated.
- The minimum length of the support rib face attached to a boss should be four times the wall thickness.

■ FIGURE 51

Guidelines for proportioning ribs

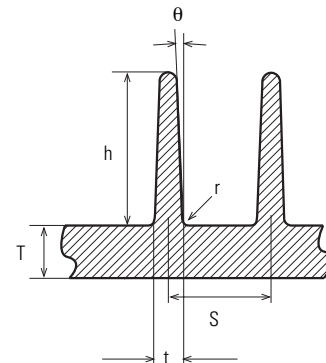

1. Base thickness $t \leq 0.5 T$
2. Height $h \leq 3 T$
3. Corner radius $r \geq 0.25 - 0.4 T$
4. Draft angle $\theta \geq 0.5^\circ$
5. Spacing $S \geq 2 T$

■ FIGURE 52

Guidelines for introducing of support ribs

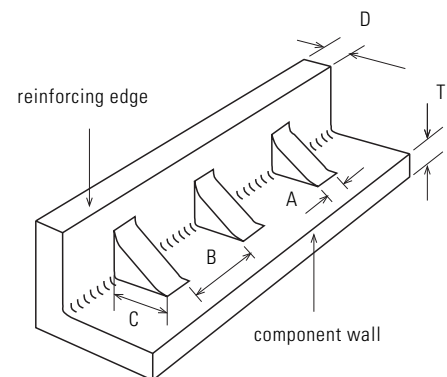

1. Component wall thickness T
2. Rib thickness A
3. Distance between successive rib faces B
4. Length of rib face attached to component C
5. Thickness of reinforcing edge D

- $0.7 T \geq A \geq 0.5 T$
- $B \geq 2 T$
- $C \geq 2 T$

■ FIGURE 53

Boss proportions that usually provide sufficient strength, though accompanied by sink marks and residual stress

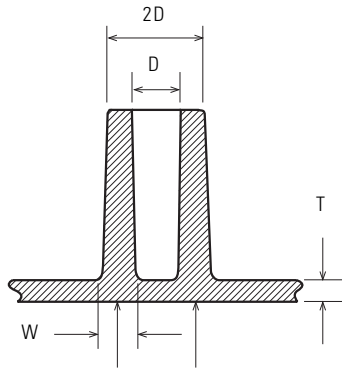

Strong possibility of sink marks when $W > 0.6 T$

■ FIGURE 54

Reduced boss section with strengthening gussets and incorporating radius

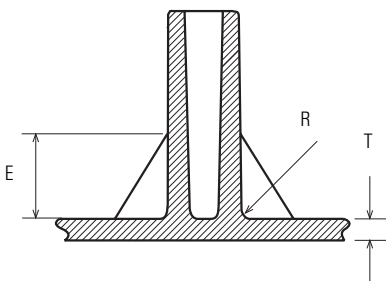

$R = 0.25 T$
 $E \geq 4 T$

■ FIGURE 55

Attaching bosses to nearby walls

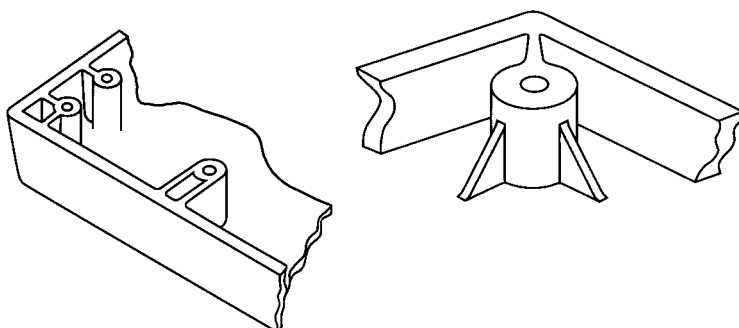

8.5.7 Bosses

Bosses are features added to the nominal wall thickness of the component and are usually used to facilitate mechanical assembly. Under service conditions, bosses are often subjected to loadings not encountered in other sections of a component. Hollow bosses may receive self-tapping screws, ultrasonic welding, press-fits or moulded-in inserts, any of which may exert an excessive hoop stress on the boss wall. This can be alleviated by the application of suggested boss design principles:

- (a) General recommendations for the thickness of projections from a nominal wall suggest a boss wall thickness of 50% to 70% of the nominal wall. This may not, however, provide sufficient strength to withstand the stresses imposed by an insert. The increased strength achieved by increasing the section is accompanied by sink marks and high residual stresses. For these reasons a compromise between aesthetics and strength is frequently required, (refer to ■ FIGURE 53).
- (b) Since external forces imposed on a boss also act on the wall from which it projects, a minimum radius of 25% of the wall thickness at the base of the boss is recommended.
- (c) Further strength may be achieved by gusset plate supports, as illustrated in ■ FIGURE 54.
- (d) Attaching the boss to a nearby wall with a rib results in increased strength. Furthermore, this assists in venting during mould filling. Examples are outlined in ■ FIGURE 55.

- (e) In order to minimize sink marks opposite the boss, it is usually necessary to ensure that the core pin partially penetrates the nominal wall. To avoid stress concentrations and to minimize material turbulence during mould filling, the head of the core pin should incorporate a generous radius.

8.5.8 Undercuts

Undercuts of part geometry in the mould should be avoided if possible through redesign. Ideally, mould tools should open in a direction parallel to the movement of the injection moulding machine. Depending on the component shape, slight undercuts can be stripped from the tool. This is provided that sufficient taper is given to avoid scuffing the surface of the component. Certain design techniques can give the desired geometry without having to use mechanical devices. Examples of these techniques are illustrated in ■ FIGURE 56.

■ FIGURE 56

Undercuts

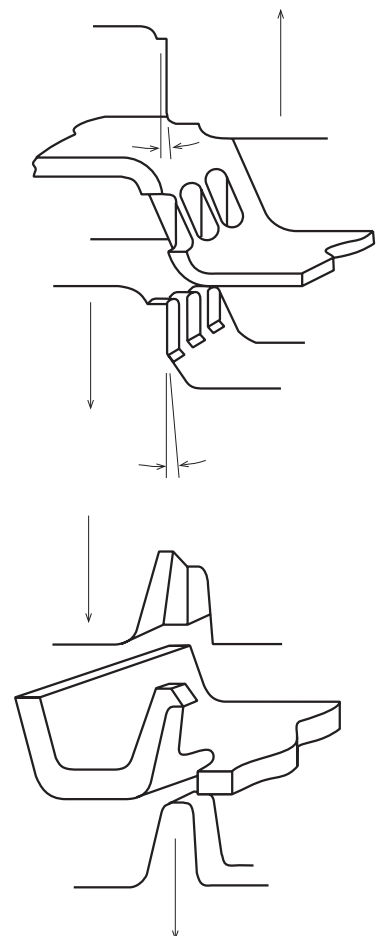

For some complex components it is necessary to use side cores, mechanically operated cams or loose cores. They can be dealt with if necessary as follows:

(a) cams:

Cams or pneumatic cylinders move part of the mould out of the way to permit ejection. They are quite expensive in that the mould layout is much more complicated to machine. Controllers are required to operate in the moulding cycle. Also the cycle time will be increased.

(b) slides:

Angled pins or rods are mounted in the mould. Part of the mould forming an undercut or hole in the component will slide in the direction of the angled pin when the mould opens. Proper ejection is then possible.

(c) deflect:

Small undercuts can often be deflected by bending out the part from the mould.

(d) inserts:

Some undercuts can be produced using removable inserts which eject with the part. This requires an extra operation to replace an insert in the mould for the next cycle and to remove the one from the ejected part.

(e) stepped parting line:

Often the parting line can be relocated so that there is no longer an undercut. This can add some complexity to the mould design but is the most recommended solution if possible.

rejoins, it forms a weld- or a flow line. This is always a weak spot in the component and may also be aesthetically undesirable.

To minimize these problems, and encourage the formation of strong weld lines, the following recommendations should be considered. Firstly, the shortest distance between the edges of any two holes or slots should be greater than twice the nominal wall thickness. Secondly, when positioning a hole or slot near to the edge of a component, the shortest distance between the edges of the hole and the component should exceed twice the nominal wall thickness.

Blind holes are created by a core supported on only one side of the tool. The core's ability to withstand the bending forces induced by the flowing polymer determines the maximum hole depth. In general, the depth of a blind hole should not exceed three times its diameter or minimum cross-sectional dimensions. For small holes with a diameter of less than 6 mm, the length:diameter ratio should be kept to 1:2.

With through holes it is possible to use longer cores as they are supported on both sides of the mould cavity. In general, for through holes the overall length of a core can be twice as long as that for a blind hole.

If the hole is to be used to mechanically fasten the component to a dissimilar material, allowances should be made for expansion and contraction. It is recommended that the diameter of the hole is greater than that of the fastener by 20%-40%, depending on

expected temperature fluctuations and differences between expansion coefficients of the materials.

8.5.10 Draft angles

In order to facilitate component removal from the mould and hence reduce cycle time, a design should incorporate appropriate draft angles. For untextured surfaces, 0.25 degrees to 2 degrees per side for both inner and outer wall is usually sufficient. In certain applications the use of draw polish on the mould surface may allow a smaller angle.

The mould parting line position on the part can often be relocated in order to change or split the required draft. If absolutely no draft is permitted due to dimensional requirements, a cam or slide in the mould may be required. An illustrated example of draft angles is given in ■ FIGURE 57.

8.5.11 Textures and lettering

Textures and lettering can often be moulded into the surface of a part. This can be very helpful in that it can serve as an aesthetic or decorative surface at no additional cost. It can also help to hide surface imperfections such as weld lines.

Textured side walls require an additional 0.4 degrees draft per 0.01 mm depth of texture, though each individual case should be discussed with the mould texturing supplier. For larger drafts, up to as much as 10 degrees may be required for particularly complex mouldings with textured finishes.

8.5.9 Coring

The term coring in the injection moulding process refers to the addition of steel to the tool in order to reduce or eliminate material from a particular area of the component.

A core which forms a hole, however, tends to limit natural material shrinkage and results in an area of relatively high residual stress around the hole. To minimize stress concentration points, irregularly shaped holes such as ventilation slots incorporating sharp internal corners should be avoided. Round holes are generally less susceptible, since the residual stresses tend to be evenly distributed. The inclusion of any hole results in an interruption of the melt as it flows around the core. Where the melt

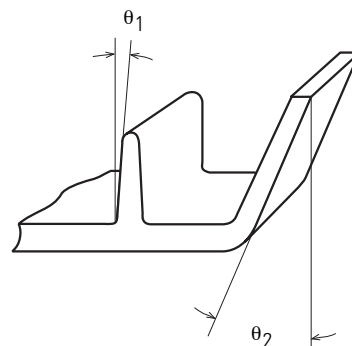

■ FIGURE 57

Guidelines for introducing of support ribs

- θ_1 0,25° - 2° for smooth surfaces
- θ_2 Larger angle required for textured surfaces and complex geometries

8.5.12 Flow leaders

Ribs and thickened sections can be designed into a part to function as flow leaders. While these can be used to help fill a part in a predetermined way, they can also lead to problems such as backfilling and inappropriate weld line locations.

Gate location and size play a big role in determining the effectiveness of flow leaders. For example, a large centre sprue gate positioned in a thick rib on a large flat part will cause the resin to flow rapidly down the rib and then fan out to fill the part.

A further example is if a large flat part has two crossing diagonal support ribs and the gate is located onto one of them. The flow will often first proceed all of the way along the ribs. When the flow front reaches the end of the ribs, resistance to flow and hence pressure will rise. In this case, the material will begin to fan out into the flat portion of the part all of the way along both ribs. The flow fronts from this fanning out can meet in the centre of the sections between the ribs forming four large weld lines in the part surface. This effect can be reduced by thinning the ribs or relocating the gates.

8.5.13 Moulded-in stress

Moulded-in stress is present in all moulded plastic parts to some degree. In general, high levels of moulded-in stress are undesirable and are caused by any of the following factors:

- high pressure in the moulding cycle
- cold tool temperature
- thin sections in high flow areas, especially in gates
- fine details at the extreme of flow
- cold flow front from long flow lengths, including runners
- sharp corners in flow path
- high viscosity materials
- cold metal inserts in the mould
- very fast cooling of plastic parts

High levels of moulded-in stress can result in:

- lack of optical clarity
- acceleration of chemical attack
- reduction in load bearing capacity
- warpage
- inability to hold tight tolerances - anisotropic shrinkage

- difficulty in painting or plating uniformly
- reduction in impact strength
- increase in ductile-brittle failure transition temperature

8.5.14 Weld lines

Weld lines are areas where two melt fronts come together and bond during the filling of a part. Weld lines will always occur where the flow front is forced to go around an obstacle, like a hole, or where flow fronts meet, for example coming from two different gates at opposite ends of the part. Because melt fronts can be marginally cooled by contact with the mould, they are often slightly less than fully molten. Thus the strength of a part in a weld line area and the levels of moulded-in stress in a weld line area are reduced and increased respectively.

Parts should be designed with respect to weld lines as follows:

- Locate weld lines in structurally non-critical areas.
- Locate weld lines in aesthetically non-critical areas.
- Texture part surface in weld line area if possible to hide aesthetic imperfection.
- Locate weld lines in areas where gussets or thickened ribs can be used to strengthen them if required. For example, if a weld line occurs on a cylindrical boss, locate a support gusset at the weld line location.
- Use diaphragm or ring gates for cylindrical parts when possible to eliminate weld lines.
- If weld lines cannot be tolerated, locate them in a removable portion of the part, as is done for overhead fluorescent light covers.

8.6 Processing considerations

8.6.1 Venting

Adequate venting is essential to the production of consistently high quality moulded parts. In general, it is better to put in more vents than the minimum required because this will facilitate flow and assure removal of gases from the mould. There are a number of problems which can result from inadequate venting:

No fill:

A trapped air pocket in the mould can cause the section of the part not to fill.

High pressure:

If air must be forced out through inadequate venting, excessive pressure may be required to fill the mould, and high levels of moulded-in stress can result.

Slower fill cycle:

If venting is inadequate, the fill cycle can be slowed down.

Tool corrosion:

Air which is trapped in a mould heats up while retaining its atmospheric moisture. This can result in tool corrosion in those areas.

Burn marks:

Trapped air pockets can heat up and parts can suffer burning or discolouration.

There are a number of common types of venting:

Parting line:

A venting system can be designed into the parting line of the mould so that trapped air can escape all of the way around the part. Parting line gates are relatively inexpensive because they can be cut into the surface of the mould along with the part geometry.

Ejector pins:

Flats can be ground onto ejector pins to produce venting by allowing the gases to escape through the gap in the round pin hole. Ejector pin gates are often used in blind pockets in the mould, such as those for part projections.

Dummy pins:

Dummy pins can be used similarly to ejector pins to provide venting in critical areas.

Vent sizes will depend upon the characteristics of the individual material and moulding parameters. Vents which are too small can be ineffective and easily clog and become useless. Vents which are too large can flash under some types of moulding conditions. The number of required vents will largely depend on the process, geometry, material and mould quality.

8.6.2 Gating

As illustrated in ■ FIGURE 58, there is a wide variety of gate types which can be used for an injection moulded component.

(a) sprue gate:

Sprue gates are usually located in the top of the centre of the part with a cold-slug-well opposite the gate. They are in general considered to be the best type of gate with respect to filling possibilities. However, they must be machined off as a secondary operation to the injection moulding process.

(b) pin point gate:

Similar to a sprue gate, the centre gate has a reverse taper and is self-degating. It is only feasible in a 3-plate tool because it must be ejected separately from the part, in the opposite direction. The gate must also be weak enough so that it will break off without damaging the part.

(c) tab gate:

A tab gate is a straight gate into the side of a part. It is very inexpensive to machine. However, it must be removed

from the part after moulding which leaves a mark on the edge or side of the part. Due to sharp angles in the gate area, melt shear can be more severe for a tab gate in comparison to the similar but preferred fan gate.

(d) fan gate:

The fan gate is similar to a tab gate but provides large blending radii to reduce shear. A fan gate must be trimmed or machined off and will leave a mark. However, it is the best type of side gate for material flow.

(e) tunnel or submarine gate:

These are very small gates on the sides of a part. They are self-degating and leave very small marks, but cause large amounts of shear in the material. Tunnel gates should have an included angle of approximately 45 degrees.

(f) jump gate:

The jump gate provides gate location on the bottom of the edge of the part. This is very desirable from an aesthetic point of view, but can be expensive to machine and cause problems with shear.

(g) diaphragm gate:

A circular gate inside the end of a cylindrical part section, the diaphragm gate is ideal for the filling of circular parts. This is because no weld line forms when the resin enters all of the way around the cylinder. However, this gate is among the most expensive to remove since it requires a mechanical operation.

(h) ring gate

In this construction, a large diameter runner goes all of the way around the outside end of a cylindrical part and material enter from all sides. As with diaphragm gates, ring gates are very good for circular section parts. They contain the weld line in the gate area and do not typically produce any weld lines in the part. However, they must also be mechanically removed. Ring gates are relatively inexpensive because they can be put in the parting line of the mould and easily machined in the mould half.

■ FIGURE 58

Common gate types

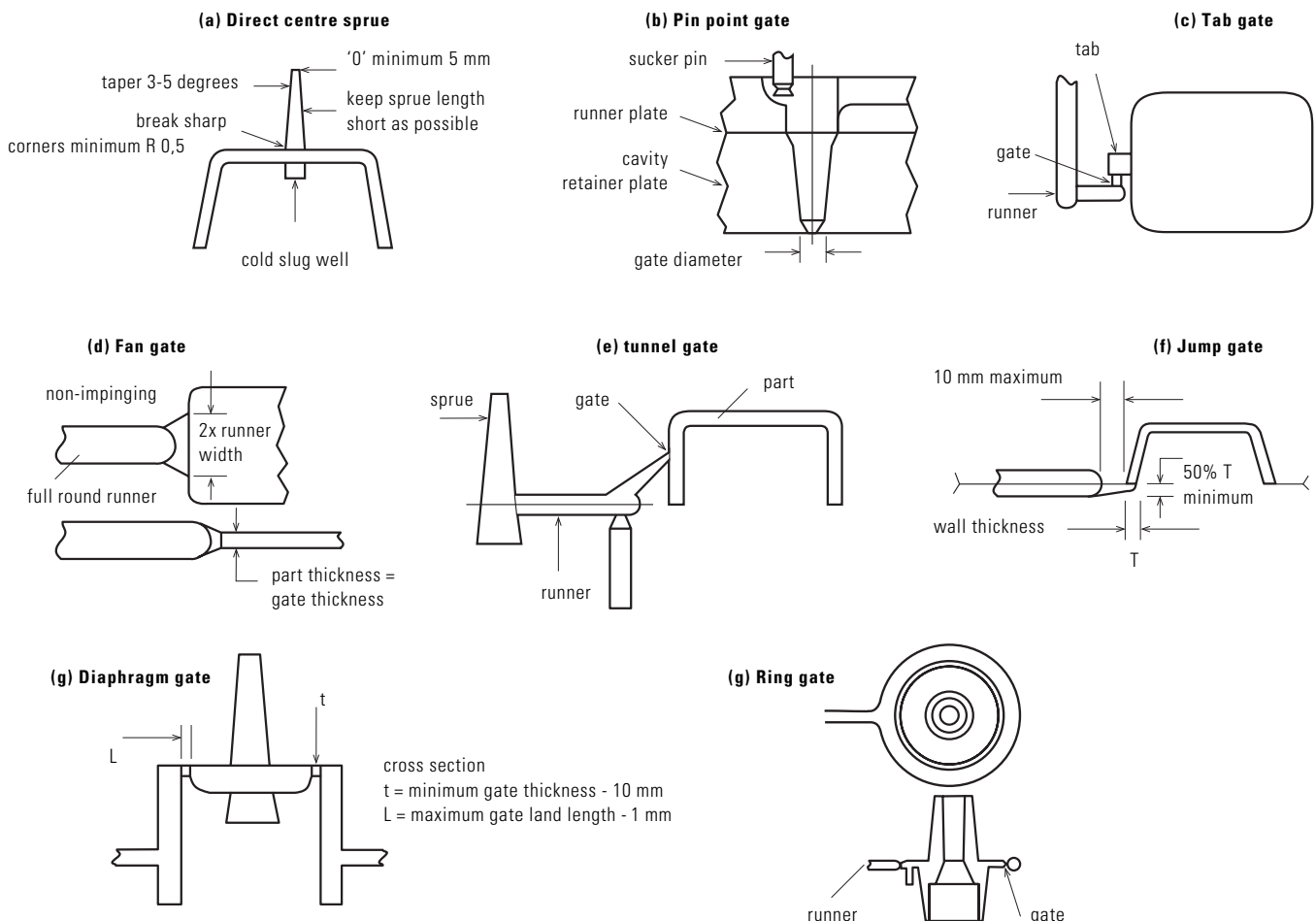

Recommendations:

As general recommendations, gates should be:

- As large as possible to permit high speed and low shear material flow
- Radiused to reduce shear and facilitate flow
- Designed to include a cold slug well to catch the cooled melt front
- Located strategically to control weld line locations and flow length
- In thicker areas for injection moulded parts

8.7 Ejection

There is a variety of ejector mechanisms used in injection moulding machines for plastic components:

(a) pins:

Pins are the most common types of ejector. Vents can often be machined on round ejector pins. Care must be taken to ensure that there are enough ejector pins of sufficient diameter to properly eject the part without damage. It is also important that the ejection force is equally spread over the part for proper ejection from the mould.

(b) blades:

Blades are very poor ejectors for a number of reasons. They often damage parts, they bend or break and require a lot of maintenance. Furthermore, rectangular slots must be machined into the mould to fit the blade ejector. Blade ejectors are most commonly used in the base of pockets which produce ribs on the part.

(c) plates:

Plates can be put in the mould to produce large ejection surfaces. Ejector plates reduce part damage on ejection.

(d) stripper bars:

A stripper bar is a type of plate which takes the form of a bar attached to some heavy duty ejector pins. The back end of a stripper bar should be tapered to prevent alignment problems.

(e) air valves:

Air valves are commonly used to assist in ejection but not as a primary ejection system. They release pressurized air when opening the valve.

9

Design for recyclability

Manufacturing economics combined with environmental concerns are forcing the design engineer to re-think the approach to product design, and consider the disposal issues arising after the product is discarded. Because of the waste disposal problems associated with plastics, it is necessary to think in terms of recyclability. This means that the material from which the 'initial' component was manufactured is reground and used for several generations of other components, each requiring a reduced material property profile compared to that of the preceding component. A typical example of a totally recyclable plastic design would be one that uses no metal components, is easily disassembled, uses no adhesives or decorative/protective finishes, and has components which are manufactured from the same resin type and grade.

To achieve a totally recyclable design is, of course, a monumental task when considering legislative, regulatory, technical and cosmetic demands, which all impose restrictions on component/product design and material selection. The key criterion for ease of recyclability is ease of disassembly which in turn is dependent on simplified assembly.

This is achieved by using fewer components through, for example, component integration, and by utilizing assembly features that can be 'designed-in' to thermoplastic components.

The following points are general guidelines for the design of new products which are intended to be recyclable.

- (a) Avoid using 'moulded-in' metal reinforcements in plastic components. These are difficult to separate and make recycling uneconomical. This also applies to metal inserts for bushings or machine screws.
- (b) Where possible avoid using self-tapping screws, and take advantage of the inherent properties of thermoplastics to design snap-fit assembly features.
- (c) Bonding and cementing with polyester- and polyurethane-based materials should be avoided as these contaminate the recycled material. If unavoidable then design 'break-out' features in the area of the bond line to facilitate removal. This also applies to welded assemblies using

induction coils or powdered metals. When applied to both bonded and welded assemblies the 'break-out' technique also facilitates rapid separation of the components.

- (d) Where possible make the components from the same material type and grade. Where this is not possible, code the components for easy identification of the material type, by, for example, using barcodes or standard moulded-in colour identification chips. When dismantling assemblies which use different resin types and grades, a coding procedure for materials enables them to be easily identified and sorted.
- (e) Avoid where possible using for example decorative paints, lacquers and protective coatings. Carefully selected resin colours in combination with surface texturing can sometimes give an ideal cosmetic appearance without having to use such coatings.
- (f) When hot-foil decoration or printing is needed, separate, easy-to-remove secondary mouldings can be used as the carrier/base.

10

Design for automation

Automation is a generic term used to describe all production methods which utilize mechanized assembly techniques. These include pick and place devices, manual manipulators and fully robotized production systems such as computer-aided manufacturing technology or advanced manufacturing techniques.

Efficiency, flexibility, economy, quality and reliability of end products are all factors in the drive towards automation. The key to automation is design. High performance engineering thermoplastics provide valuable opportunities for greater integration of functions than can be achieved with traditional construction materials such as metal, wood or glass. Such integration results in fewer components and reduced inventory, but requires a new approach to product design.

Automation is an integral part of product design which must be considered at the initial design stage. The following points should be viewed as guidelines when designing for automation:

- * Assembly can be rationalized through product design by simplifying component assembly or by eliminating it through component integration.

- * Integration of functions reduces components and sub-assemblies and creates larger, more easily handled parts.

- * Reducing the number of components to a minimum is essential to facilitate rapid assembly.

- * It is good design practice to create a chassis as the carrier, with all components being fixed by snap-fit features 'on-line'.

- * Snap-fit features should be designed into components wherever possible, as screws and bayonet fixings are among the most difficult fastenings to assemble.

- * Components should incorporate guide surfaces and location features to help position components for ease of assembly.

- * It can be generally assumed that products which are well-designed for automated assembly are equally easy to assemble manually.

- * Components that are equally easy to assemble and dismantle provide a good basis for recycling.

11

Appendix

Complementary reading

Roark's formulae for Stress and Strain

Warren C. Young
McGraw-Hill Book Company, New York

Modern Plastics Encyclopedia

McGraw-Hill Book Company, New York

Mechanics of Materials

H.J. Hearn
Longman Press, London

Design Engineering

R.J. Matousec
Hermes Verlag, Berlin

Mechanical testing of materials

A.J. Ferner George Newnes Ltd.,
London

Structural design with Plastics

B.S. Benjamin
Van Norstrand, New York

Designing with Plastics

G.W. Ernstein and G. Erhard
McMillan Publishing Company,
New York

Polymer Engineering

H. Leverne Williams
Elsevier Scientific Publishing, Oxford

Konstruieren mit Kunststoffen

G. Schreger
Hanser Verlag, Munich

Engineering Thermoplastics

J. Margous
Marcel Dekker Inc., New York

Thermoplastics: Materials Engineering

L. Mascia
Applied Science Publishing Ltd.,
London

Plastics materials

J.A. Brydson
Butterworth Scientific, London

Machinery's Handbook

E. Oberg, F.D. Jones, H.L. Horton
Edited by H.L. Ryffel
Industrial Press Inc., New York



GE Plastics

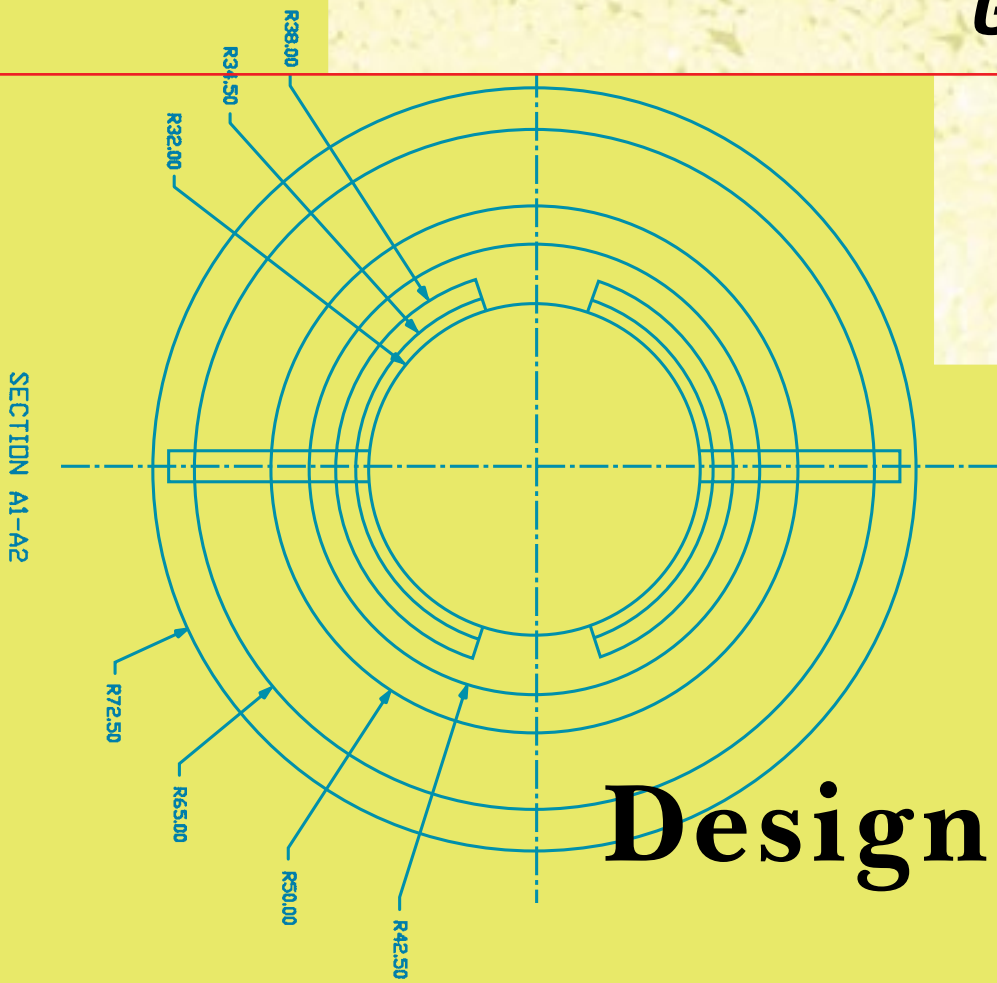

Design guide

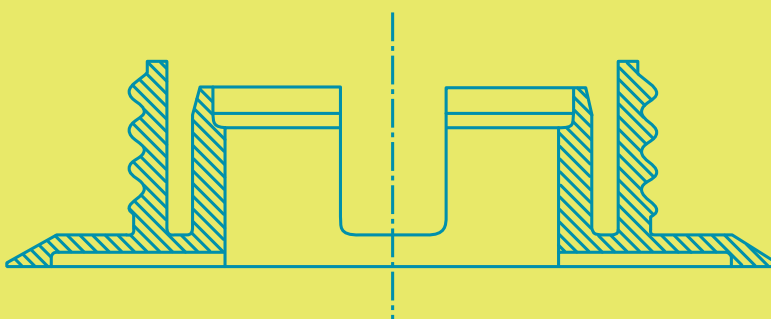
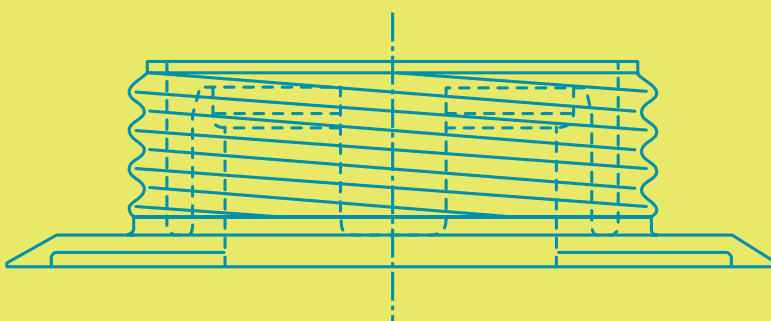

GE Plastics in Europe

European Headquarters

General Electric Plastics B.V.
1 Plasticslaan, PO Box 117
NL - 4600 AC Bergen op Zoom
The Netherlands
Tel. (31) (164) 29 29 11
Fax (31) (164) 29 29 40

Headquarters Sales Region

General Electric Plastics B.V.
Gagelboslaan 4
NL - 4623 AD Bergen op Zoom
The Netherlands
Tel. (31) (164) 29 23 91
Fax (31) (164) 29 17 25

Benelux Sales Region

General Electric Plastics B.V.
Gagelboslaan 4
NL - 4623 AD Bergen op Zoom
The Netherlands
Tel. (31) (164) 29 11 92
Fax (31) (164) 29 17 25

United Kingdom

GE Plastics Limited
Old Hall Road
Sale
Cheshire M33 2HG United Kingdom
Tel. (44) (161) 905 50 00
Fax (44) (161) 905 51 19

Germany

General Electric Plastics GmbH
Eisenstraße 5
D - 65428 Rüsselsheim Germany
Tel. (49) (6142) 6010
Fax (49) (6142) 65746

France

General Electric Plastics France S.à.R.L.
Z.I. St. Guénault B.P. 67
F - 91002 Evry-Cedex France
Tel. (33) (1) 60 79 69 00
Fax (33) (1) 60 77 56 53

Italy

General Electric Plastics Italia S.p.A.
Viale Brianza, 181
I - 20092 Cinisello Balsamo (Milano) Italy
Tel. (39) (02) 61 83 41
Fax (39) (02) 61 83 42 11

Russia

General Electric International A/O
Kosmodamianskaia Nab, 52
Building 1
113054 Moscow Russia
Tel. (7) (095) 935 7312
Fax (7) (095) 935 7317

Spain

General Electric Plastics Ibérica S.A.
Avenida Diagonal, 652-656
Edificio D. Planta 3
08034 Barcelona Spain
Tel. (34) (93) 252 16 00
Fax (34) (93) 280 26 19

Sweden

GE Plastics Limited
Box 1242, Skeppsbron 44
S-11182 Stockholm Sweden
Tel. (46) (8) 402 40 24
Fax (46) (8) 723 12 92

Turkey

GE Plastics Turkey
Is Bankasi Blokleri
Cemil Topuzlu Caddesi
A Blok, Daire 18
81030 Feneryolu
Istanbul Turkey
Tel. (90) (216) 386 7104
Fax (90) (216) 386 5812

GE Plastics in India

GE Plastics India Ltd.

405-B, Sector 20
Udyog Vihar Phase - III
Gurgaon, Haryana - 122 016, India
Tel. (91) 124 341 801 to 806
Fax (91) 124 341 817 or 815

GE Plastics in South Africa

GE Plastics South Africa

General Electric South Africa (Pty) Ltd.
15th floor Sandton Office Tower
Sandton 2146
Johannesburg, South Africa
Tel. (27) 11 784 2108
Fax (27) 11 784 2216

GE Plastics in the Americas

Worldwide Headquarters

United States
GE Plastics
1 Plastics Avenue
Pittsfield, MA 01201
USA
Tel. (1) (413) 448 7110
Fax (1) (413) 448 7493

Canada

GE Plastics Canada Ltd.
2300 Meadowvale Boulevard
Mississauga, Ontario L5N 5P9
Canada
Tel. (1) (905) 858 5774
Fax (1) (905) 858 5798

Mexico

GE Plastics - Mexico S.A. de C.V.
Av. Prolongacion Reforma #490, 4o. piso
Colonia Santa Fe
01207 Mexico, D.F.
Tel. (11) 525 257 6060
Fax (11) 525 257 6070

Brazil

GE Plastics South America S.A.
Av. Nações Unidas, 12995 - 20º andar -
Cep 04578.000
São Paulo - SP
Brazil
Tel. (55) 11 5505 2800
Fax (55) 11 5505 1757

GE Plastics in the Pacific

Pacific Headquarters

GE Plastics Pacific Pte. Ltd.
240 Tanjong Pagar Road
GE Tower #09-00
Singapore 0208
Tel. (65) 326 3301
Fax (65) 326 3303/(65) 326 3290

Australia

GE Plastics Australia
175 Hammond Road
Dandenong, Victoria 3175
Australia
Tel. (61) 3 794 4201
Fax (61) 3 794 8563

China

GE Plastics China
Beijing, 3rd floor
CITIC Bldg. No.19
Jian Guo Men Wai Avenue
Beijing 100004
China
Tel. (86) (21) 270 6789
Fax (86) (1) 512 7345

Hong Kong

GE Plastics Hong Kong Ltd.
Room 1088 - Tower 1
The Gateway, Tsimshatsui
Kowloon
Hong Kong
Tel. (852) 2629 0827
Fax (852) 2629 0800

Japan

GE Plastics Japan Ltd.
Nihombashi Hamacho Park Building
2-35-4, Nihombashi-Hamacho
Chuo-ku, Tokyo 103
Japan
Tel. (81) 3 5695 4888
Fax (81) 3 5695 4859

Korea

GE Plastics Korea Co. Ltd.
231-8 Nonhyun-Dong
Kangnam-Ku
Seoul 135-010
Republic of Korea
Tel. (82) 2 510 6250/1
Fax (82) 2 510 66 66/7

Singapore

GE Plastics Singapore Pte Ltd.
c/o 23 Benoi Road
Singapore 2262
Tel. 65 846 3290
Fax 65 861 3063

Taiwan

GE Plastics Taiwan
9/F 37 Min Chuan East Road Sec 3
Taipei 10462
Taiwan, Rep. of China
Tel. (886) 2 509 2124/6
Fax (886) 2 509 1625

Thailand

GE Plastics Thailand
21st Floor
Thaniya Plaza Building
52 Silom Road
Bangkok 10500
Thailand
Tel. (66) (2) 231 2323
Fax (66) (2) 231 2322

DISCLAIMER: THE MATERIALS AND PRODUCTS OF THE BUSINESSES MAKING UP THE GE PLASTICS UNIT OF GENERAL ELECTRIC COMPANY*, USA, ITS SUBSIDIARIES AND AFFILIATES ("GEP"), ARE SOLD SUBJECT TO GEP'S STANDARD CONDITIONS OF SALE, WHICH ARE INCLUDED IN THE APPLICABLE DISTRIBUTOR OR OTHER SALES AGREEMENT, PRINTED ON THE BACK OF ORDER ACKNOWLEDGMENTS AND INVOICES, AND AVAILABLE UPON REQUEST. ALTHOUGH ANY INFORMATION, RECOMMENDATIONS, OR ADVICE CONTAINED HEREIN IS GIVEN IN GOOD FAITH, GEP MAKES NO WARRANTY OR GUARANTEE, EXPRESS OR IMPLIED, (I) THAT THE RESULTS DESCRIBED HEREIN WILL BE OBTAINED UNDER END-USE CONDITIONS, OR (II) AS TO THE EFFECTIVENESS OR SAFETY OF ANY DESIGN INCORPORATING GEP MATERIALS, PRODUCTS, RECOMMENDATIONS OR ADVICE. EXCEPT AS PROVIDED IN GEP'S STANDARD CONDITIONS OF SALE, GEP AND ITS REPRESENTATIVES SHALL IN NO EVENT BE RESPONSIBLE FOR ANY LOSS RESULTING FROM ANY USE OF ITS MATERIALS OR PRODUCTS DESCRIBED HEREIN. Each user bears full responsibility for making its own determination as to the suitability of GEP's materials, products, recommendations, or advice for its own particular use. Each user must identify and perform all tests and analyses necessary to assure that its finished parts incorporating GEP materials or products will be safe and suitable for use under end-use conditions. Nothing in this or any other document, nor any oral recommendation or advice, shall be deemed to alter, vary, supersede, or waive any provision of GEP's Standard Conditions of Sale or this Disclaimer, unless any such modification is specifically agreed to in a writing signed by GEP. No statement contained herein concerning a possible or suggested use of any material, product or design is intended, or should be construed, to grant any license under any patent or other intellectual property right of General Electric Company or any of its subsidiaries or affiliates covering such use or design, or as a recommendation for the use of such material, product or design in the infringement of any patent or other intellectual property right.

* Company not connected with the English company of a similar name.

Lexan®, Noryl®, Noryl® GTX®, Noryl® Xtra, Valox®, Ultem®, Xenoy®, Cyclocac®, Cycloyol® and Enduran® are Registered Trademarks of General Electric Co., USA.

Gelon™ is a Trademark of General Electric Co., USA.

